

# AIRMAN

---

# PC

---

## INSTRUCTION MANUAL

### ENGINE COMPRESSOR

### **PDS185S-6E1**

Please be sure to read this manual  
before using this machine.

**HOKUETSU INDUSTRIES CO., LTD.**

# Preface

Thank you for having selected our "AIRMAN" product.

- ◆ This manual explains about the proper operation and daily inspection and maintenance of this machine.
- ◆ In order to use the machine safely, people with sufficient knowledge and sufficient technology need to deal with it.
- ◆ Before operating the machine, read the manual carefully, fully understand its operation and maintenance requirement. Maintain "SAFETY OPERATION AND PROPER MAINTENANCE OF THE MACHINE".

Be sure to follow safety warnings and cautions given in the manual.  
 Unsafe operation could cause serious injury or death.

- ◆ For details of handling, maintenance and safety of the engine, see the Engine Operation Manual.
- ◆ Keep the manual available at all times for the operator or safety supervisor.
- ◆ When this manual is missing or damaged, order it from our office nearby or distributor.
- ◆ Be sure that the manual is included with the machine when it is handed over to another user.
- ◆ There may be some inconsistency in detail between the manual and the actual machine due to improvements of the machine. When you have anything unclear or you want to advise us, contact our office nearby or distributor.
- ◆ If you have any questions about the machine, please inform us the model and serial number. A plate stamped with the model and serial number is attached to side of the machine.

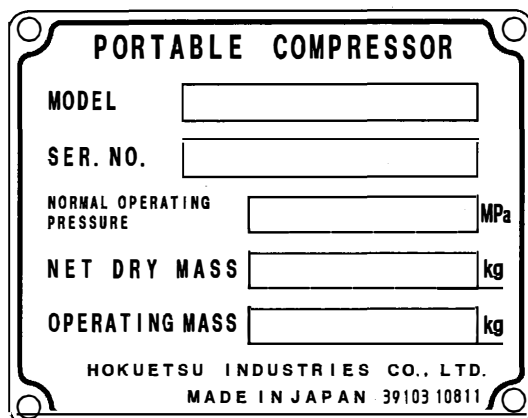

A130375

- ◆ Each illustrated figure (Fig.) has a number (for instance, A130375) at the right bottom. This number is not a part number, but it is used only for our reference number.

# Table of Contents

<b>1. Safety</b>	<b>1-1</b>
1.1 Caution before Operation	1-2
1.2 Caution during Operation	1-5
1.3 Caution during Inspection and Maintenance	1-7
1.4 Safety Warning Labels	1-10
<b>2. Part Names</b>	<b>2-1</b>
2.1 Internal Components and Part Names	2-1
<b>3. Installation</b>	<b>3-1</b>
3.1 Transportation	3-1
3.2 Towing the Unit	3-2
3.3 Installation	3-3
<b>4. Operation</b>	<b>4-1</b>
4.1 Instrument Panel	4-1
4.2 Lubricant • Coolant • Fuel	4-2
4.3 Check before Starting Unit	4-4
4.4 Operation	4-8
4.5 Capacity Control Device	4-12
4.6 Stopping	4-14
4.7 Air bleeding in fuel line	4-14
4.8 DPF Regeneration	4-15
<b>5. Failure cause and measures</b>	<b>5-1</b>
5.1 Indicator lamp and Warning / Emergency display	5-1
5.2 Troubleshooting	5-2
5.3 Adjustment of Various data	5-4
<b>6. Periodic Inspection/Maintenance</b>	<b>6-1</b>
6.1 Important Items as Periodic Inspection and Maintenance or after Maintenance	6-1
6.2 Daily Inspection and Operation Log	6-2
6.3 Periodic Inspection List	6-3
6.4 Periodic Replacement of Parts	6-5
6.5 Maintenance Items	6-6
<b>7. Long-term Storage and Disposal of Product</b>	<b>7-1</b>
7.1 Preparation for Long-term Storage	7-1
7.1 Disposal of Product	7-1
<b>8. Specifications</b>	<b>8-1</b>
8.1 Specifications	8-1
8.2 Outline drawing	8-2
<b>9. Wiring Diagram</b>	<b>9-1</b>
<b>10. Piping Diagram</b>	<b>10-1</b>
10.1 Air piping • Compressor oil piping	10-1
10.2 Fuel piping	10-2

# 1.Safety

---

This manual explains and illustrates general requirements for safety.

Read all safety requirements carefully and fully understand the contents before starting the machine.

For your better recognition, according to the degree of potential danger, safety messages are classified into three hierarchical categories, namely, "DANGER", "WARNING" and "CAUTION" with a caution symbol  -attached to each message.

When one of these messages is shown, please take preventive measures and carry out "SAFETY OPERATION AND PROPER MAINTENANCE OF THE MACHINE".



**DANGER** indicates an imminently hazardous situation which, if not avoided by any user, will result in death or serious injury. This signal word is to be limited to the most extreme situations.



**WARNING** indicates a potentially hazardous situation which, if not avoided, could result in death or serious injury to a user.



**CAUTION** indicates a potential hazardous situation which may possibly only cause a minor injury to a user and damages to property only.



**IMPORTANT** indicates important caution messages for the performance or durability of the machine.

Follow warnings mentioned in this manual. This manual does not describe all safety items.

We, therefore, advise you to pay special attention to all items (even though they may not be described in the manual) for your safety.

# 1.Safety

## 1.1 Caution before Operation

### **DANGER**

***Compressed air is prohibited to be used for human respiration***

- Compressed air by this machine contains poisonous materials. Absorption of the compressed air can cause serious injury. Never provide this compressed air for human respiration.
- This machine is not designed to be used for working chambers pressurized by compressed air such as respiratory air provided to persons working inside wells and tunnels such as pneumatic engineering method and pneumatic caisson method. Should this machine stop operation due to trouble, it can cause death and serious injury to the working persons. Refrain from using the compressed air for such pneumatic engineering method or pneumatic caisson method.

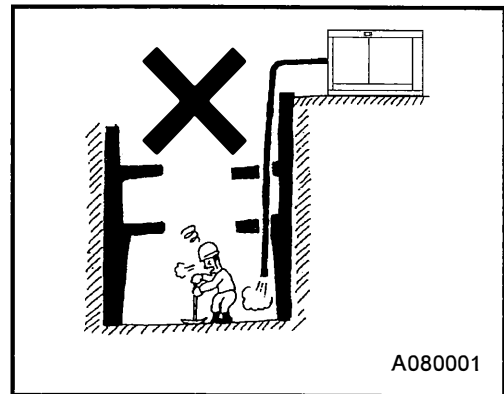
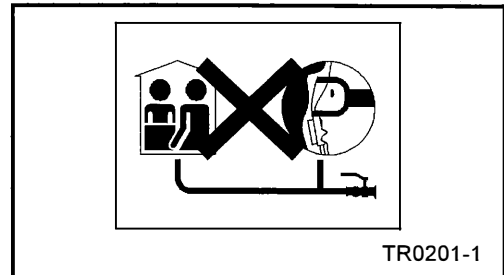

### **WARNING**

***Follow the safety instructions***

- Read each instruction plate which is displayed in the manual or on the machine carefully, understand its content and follow the indications thereof.
- Keep the Safety Warning labels clean. When they are damaged or missing, apply new ones.
- Do not modify the machine without prior approval. The safety may be compromised, functions may be deteriorated, or the machine life may be shortened.
- Never use the machine for the purpose of compression of gases other than air, or as a vacuum pump. Otherwise, serious accidents may occur.

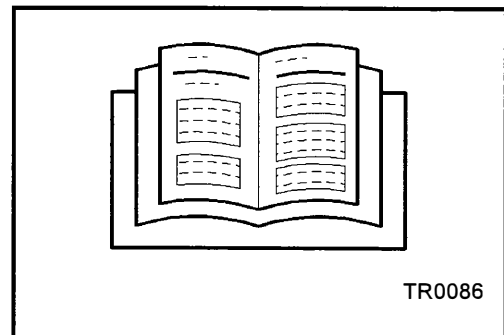

### **WARNING**

***Ventilation***

- Exhaust gas from the engine is poisonous, and could cause death when inhaled. Avoid using the machine in an insufficiently ventilated building or tunnel.

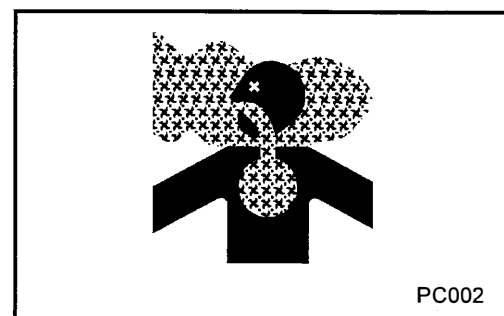

# 1. Safety

## WARNING

- Keep flames away from battery.
- Battery may generate hydrogen gas and may explode.
- Battery electrolyte is dilute sulfuric acid.  
In case of mishandling, it could cause skin burning.
- When you deal with a battery, please be sure to wear protection implements, such as protection glasses and a glove.
- Dispose of battery, observing local regulations.

## Handling battery

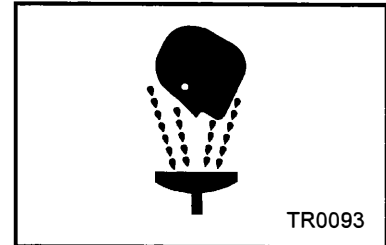

## WARNING

## Cautions of hose attachment and removal

- Piping or the hose from this machine service valve should use what can be borne enough for the discharge pressure of this machine.
- Please connect piping or a hose to this machine service valve firmly before operation and during operation. If the connection part is loosening, there is a possibility of piping or a hose separating and getting seriously injured.
- Please remove after closing a service valve and extracting pressure remained, in case piping or a hose is removed. If pressure remained should remain, a near thing blows away or there is a possibility of a hose whipping, causing a phenomenon and getting seriously injured.
- In order to use it safely, please read the handling of the work tools often used.

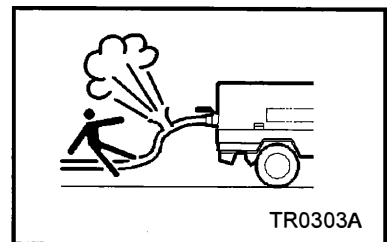
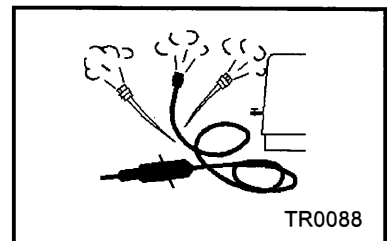

## WARNING

## Safety outfit

- When handling the machine, do not wear;
- Loose clothes
- Clothes with unbuttoned sleeves
- Hanging tie or scarf
- Accessories such as dangling jewelry
- Such outfit could be caught in the machine or dragged in the rotating portion of the machine, and this could cause a serious injury.



# 1.Safety

## WARNING

### **Maintain both physical and mental health**

- Do not operate the machine when you are tired or drunk or under the influence of drugs. Otherwise, a hasty conclusion or careless handling may cause unexpected injury or accident.  
Manage your physical and mental health and be cautious in handling the machine.

## CAUTION

### **Protection equipments**

- Please wear protection implements, such as a helmet, protection glasses, earplugs, safety shoes, a glove, and a protection-against-dust mask, according to the contents of work for safety.

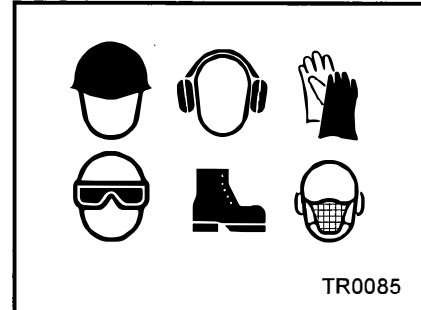

## CAUTION

### **Safety fittings**

- Have first-aid boxes and fire extinguishers near the machine ready for emergency situations such as injuries and a fire.
- It is advisable to have a list of phone numbers of doctors, ambulance and the fire department available in case of emergency.



## CAUTION

### **Safety around the machine**

- Such things as unnecessary equipment and tools, cables, hoods, covers and pieces of wood which are a hindrance to the job, have to be cleaned and removed. This is because operators and/or personnel nearby may stumble on them and may be injured.

# 1. Safety

## 1.2 Caution during Operation

### WARNING

#### ***Do not replenish compressor oil during operation***

- Do not, under any circumstance, open the oil filler cap of separator receiver tank while running or immediately after stopping operation.  
It is very dangerous because the oil filler cap could be blown off and high temperature compressed air and oil could jet out from the filler port, and cause serious injury.

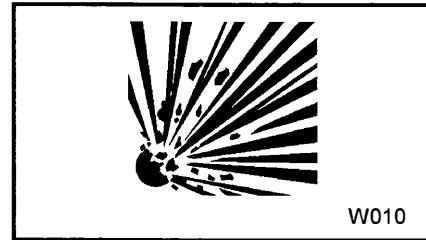

### WARNING

#### ***Draining during operation prohibited***

- Do not, under any circumstance, open the portions below during operation:
  - Separator receiver tank drain valve
  - Coolant drain valve and plug
  - Engine oil drain valve
  - Oil cooler drain valve
  - Fuel tank drain valve and plug



### WARNING

#### ***Never direct the compressed air to people and foods***

- Never blow compressed air directly at people.  
Scattered impurities, dust, or foreign objects in the compressed air may cause skin and eyes to be seriously injured.
- Blowing compressed air on food is prohibited.

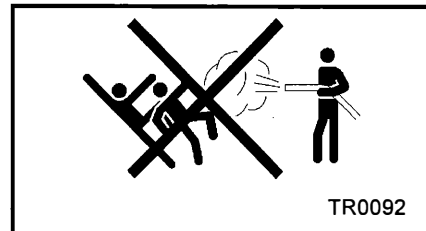

### WARNING

#### ***Hands off from rotating parts and belts***

- Keep hands off from the rotating portion or belts while running.  
It could cause serious injuries if hands should be caught in.



### CAUTION

#### ***Do not remove radiator cap during operation***

- Do not, under any circumstance, open the radiator cap while running or immediately after stopping operation.  
Otherwise high temperature steam jets out and this could cause scalding.

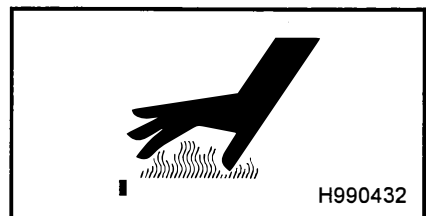



# 1. Safety

## CAUTION

**Operation with compressed air supply port opened is prohibited**

- Do not operate the machine with service valves and relief valve open unless air hoses and/or pipes are connected. High-pressurized air blows out and its air pressure could cause injury to the people nearby.
- When the machine has to be unavoidably temporarily operated with its port open, be sure to mount a silencer to reduce noise and wear protective materials such as earplugs to prevent damage to hearing.

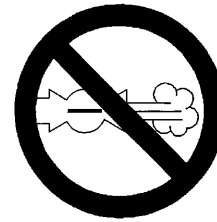

D003

## CAUTION

**Do not touch hot parts**

- Never work nearby hot portions of the machine while it is running.
- Do not touch hot portions of the machine while inspecting the machine when running.
- Such parts as engine, exhaust manifold, exhaust pipe, muffler, radiator, oil cooler, air-end, pipe, separator receiver tank, and discharging pipe are especially hot, so never touch those parts, because it could cause serious burns.
- Compressor oil, coolant water, and engine oil are also very hot and dangerous to touch. Avoid checking or refilling them while the machine is running.

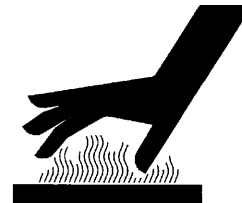

H990432

## CAUTION

**Fire prevention**

- Do not, under any circumstance, bring lit cigarettes or matches near such oils as engine oil and compressor oil, etc. They are extremely flammable and dangerous, so be careful when handling.
- Refilling oils should be done in an outdoor well-ventilated place.
- Refuel after stopping the engine, and never leave the fuel nearby the machine. Do not spill. It may cause a fire. When it is spilt, wipe it up completely.
- **Do not fill fuel oil up to the cap level. When fuel tank is filled up to the cap level, fuel oil will be overfilled due to volume expansion caused by rise of ambient temperature. Further, fuel will be possibly spilled from fuel tank due to vibration caused during movement and/or transportation of the machine.**
- Such parts as muffler and exhaust pipe can be extremely hot. Remove twigs, dried leaves, dried grass and waste paper, etc. from the exhaust outlet of the muffler.
- Keep a fire extinguisher available by the machine in case of a fire.



D004



H990433

# 1. Safety

## 1.3 Caution during Inspection and Maintenance

**WARNING**

**Hang a "Now Checking and under Maintenance" tag**

- Remove the starter key from the starter switch before starting inspection, and hang up a "Now Checking and under Maintenance" tag where it can be easily seen. The checker must keep the key during checking and maintenance.
- Remove the negative (-) side cable from the battery. If the above procedure is neglected, and another person starts operating the machine during check or maintenance, it could cause serious injury.

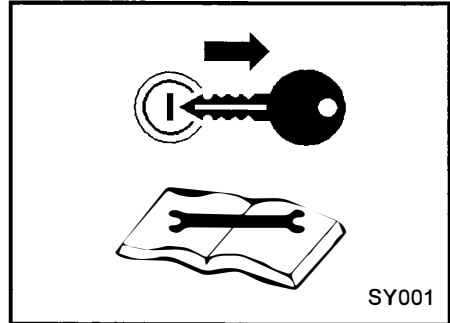

SY001

**WARNING**

**Refilling of compressor oil**

- When you refill the separator receiver tank with compressor oil, stop the engine, and make sure that the pressure gauge indicates 0psi(0bar) and there is no residual pressure in it, and then gradually loosen the oil filler cap for refilling oil.
- Note residual pressure in the separator receiver tank could force both extremely hot compressed air and oil to jet out and you may be scalded or seriously injured.

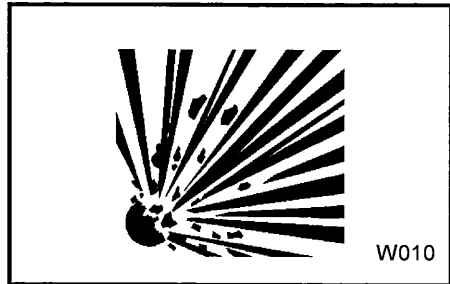

W010

**WARNING**

**Be careful of high-pressurized air blowout**

- After stopping the engine, make sure that pressure gauge indicates 0psi(0bar). Even when the gauge shows 0MPa, open a service valve and further do not fail to make sure that there is no residual pressure in the air piping. Then start such a job as repair and maintenance.
- Residual air under pressure will blow off and severely injure operator.

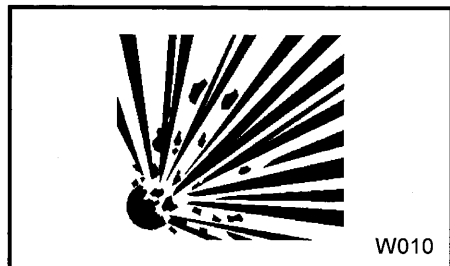

W010

**WARNING**

**Draining separator receiver tank**

- After stopping the engine, confirm that the pressure gauge indicates 0psi(0bar) and there is no residual pressure in it, then open the drain valve gradually to drain the compressor oil.
- Note residual pressure in the separator receiver tank could force both extremely hot compressed air and oil to jet out and you may be scalded or seriously injured.

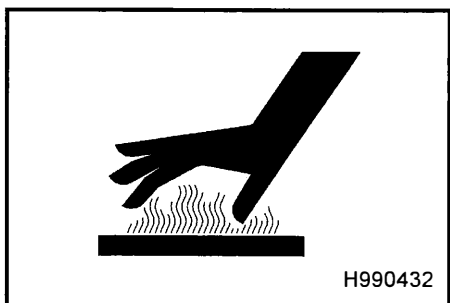

H990432

# 1. Safety

## **WARNING**

- Be sure to stop the engine and remove the starter key whenever the tension of the belt is to be adjusted.
- Remove the negative (-) side cable from the battery.
- If the machine is running, it might catch the operator's hand into the belts, and this could cause a serious injury.

### **Adjusting tension of belt**

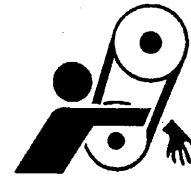

TR0304

## **WARNING**

- Be sure to stop the engine and remove the starter key whenever check or maintenance work is carried out near the cooling fan.
- If the cooling fan is rotating, it may catch the operator or part of his body into the fan, and it could cause a serious injury.

### **Hands off from cooling fan**

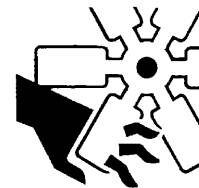

W009

## **WARNING**

- When cleaning dust accumulated in such devices as the air-filter, by blowing compressed air, wear safety glasses, etc. to protect your eyes.

### **Cleaning by air-blow**



M003

## **CAUTION**

- It is recommended to use a lamp with safety guard fitted where the site is dark. Operating the machine gropingly or by relying on one's intuition could cause unexpected accidents.
- Any lamps without safety guard are not recommended since they can be broken and they could ignite flammables such as fuel, etc.

### **Lighting apparatus**

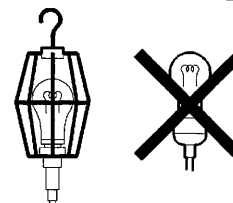

TR0206

## **CAUTION**

- Be sure to stop the engine, and let the coolant water sufficiently cool down before draining it.
- If the drain valve is opened before the coolant water is cooled enough, hot water could jet out, and it could cause scalding.

### **Opening coolant water drain valve cap**



H990432

# 1.Safety

## CAUTION

### Refilling or draining of engine oil

- After stopping the engine, wait for 10 to 20 minutes until the engine oil cools off. Then check the level of the engine oil, or refill or drain the oil.
- The engine oil is very hot during operation and just after it stops. Be careful because the hot oil also pressurized blows off and it can cause burning.

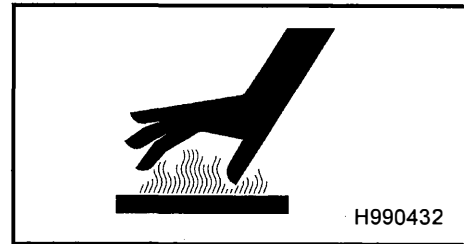

## CAUTION

### Fear of fire

- Be sure to perform the periodical check of compressor oil and oil separator.
- Neglecting checks could cause overheat of the oil, resulting in a fire.

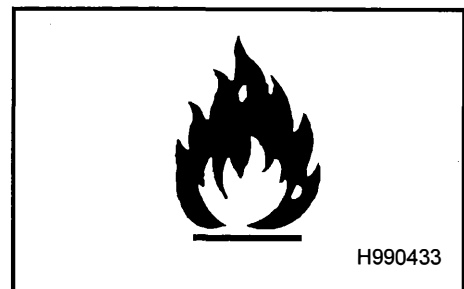

## CAUTION

### Handling of electrical equipment engine

- The engine of this machine and electrical parts many electronic devices have been installed. If you do this please go airborne welding work, remove the connector of the electronic control equipment.  
Can cause equipment to malfunction due to electronic control of excessive current is applied.

## CAUTION

### Treatment of organic wastes

- Waste liquid from the machine contains harmful material. Do not discharge it onto the ground or into the river, lake or sea. Such material will contaminate the environment.
- Be sure to use a container to hold the waste liquid from the machine.
- Be sure to follow the designated regulations when disposing of oil, fuel, coolant (antifreeze), filter, battery or other harmful materials.

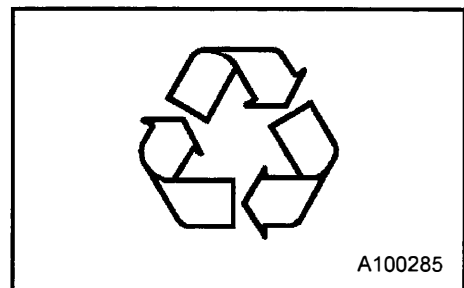

# 1. Safety

## 1.4 Safety Warning Labels

Following labels are attached to the machine.

Keep them clean at all times. If they are damaged or missing, immediately place an order with your nearest dealer for replacement. Part numbers are indicated on the lower right corner of the label.

Adhere a new one to the original location.

1	2	3	4	5
 <p><b>▲ DANGER</b></p> <p><b>DO NOT BREATHE COMPRESSED AIR</b></p> <p>Do not use this compressed air for breathing air because it can cause fatal accidents. Never breathe it.</p> <p style="text-align: right;">39176 73600</p>	 <p><b>▲ WARNING</b></p> <p><b>BEWARE OF EXHAUST GASES</b></p> <p>When you operate machine INDOORS or in TUNNEL, provide good ventilation. Poor ventilation can cause fatal accident.</p> <p style="text-align: right;">39176 73300</p>	 <p><b>▲ WARNING</b></p> <p><b>BEWARE OF RESIDUAL PRESSURE</b></p> <p>Release residual pressure inside pipings and hoses and then disconnect them. Disconnection with residual pressure still left can cause serious injury.</p> <p style="text-align: right;">39176 73400</p>	 <p><b>▲ CAUTION</b></p> <p><b>PREVENT BURNING ACCIDENT</b></p> <p>Do not open radiator cap while it is still hot.</p> <p style="text-align: right;">39176 69600</p>	 <p><b>▲ CAUTION</b></p> <p><b>PREVENT BURNING ACCIDENT</b></p> <p>When work is required near hot parts, wait for the parts to cool down fully before starting work.</p> <p style="text-align: right;">39176 69500</p>
6	7	8	9	10
 <p><b>▲ WARNING</b></p> <p><b>BEWARE OF HIGH PRESSURE AIR BLOW OUT</b></p> <p>Oil supply and/or maintenance jobs with residual pressure left in tank are very dangerous. So release the residual pressure first.</p> <p style="text-align: right;">39176 69800</p>	 <p><b>▲ CAUTION</b></p> <p><b>PREVENT FIRE ACCIDENT</b></p> <p>Periodically check compressor oil and oil separator surely. Failure of this fire accident.</p> <p style="text-align: right;">39176 69700</p>	 <p><b>▲ WARNING</b></p> <p><b>BEWARE OF ENTANGLEMENT</b></p> <p>Keep your hands AWAY from fan during operation. Entanglement in the fan can cause serious injury.</p> <p style="text-align: right;">39176 73500</p>	 <p><b>▲ WARNING</b></p> <p><b>BEWARE OF ENTANGLEMENT</b></p> <p>Keep your hands AWAY from moving parts such as V-belts, pulleys etc.. Entanglement in them can cause serious injury.</p> <p style="text-align: right;">39176 73800</p>	 <p><b>LIFTING BAIL</b></p> <p style="text-align: right;">39176 69300</p>
11	12			
 <p><b>▲ DIESEL FUEL</b></p> <p><b>EPA REGULATION</b></p> <p>ULTRA LOW SULFOR FUEL ONLY.</p> <p>DIESEL A TRES FAIBLE TENEUR EN SOUFRE UNIQUEMENT.</p> <p style="text-align: right;">39176 22031</p>	 <p><b>▲ CAUTION</b></p> <p><b>TOW MACHINE LEVEL TO ELIMINATE POSSIBLE STRESS OF COMPRESSOR FRAME STRUCTURE</b></p> <p style="text-align: right;">39176 37310</p>			

# 1.Safety

- The pasting position of safe warning label is as follows.

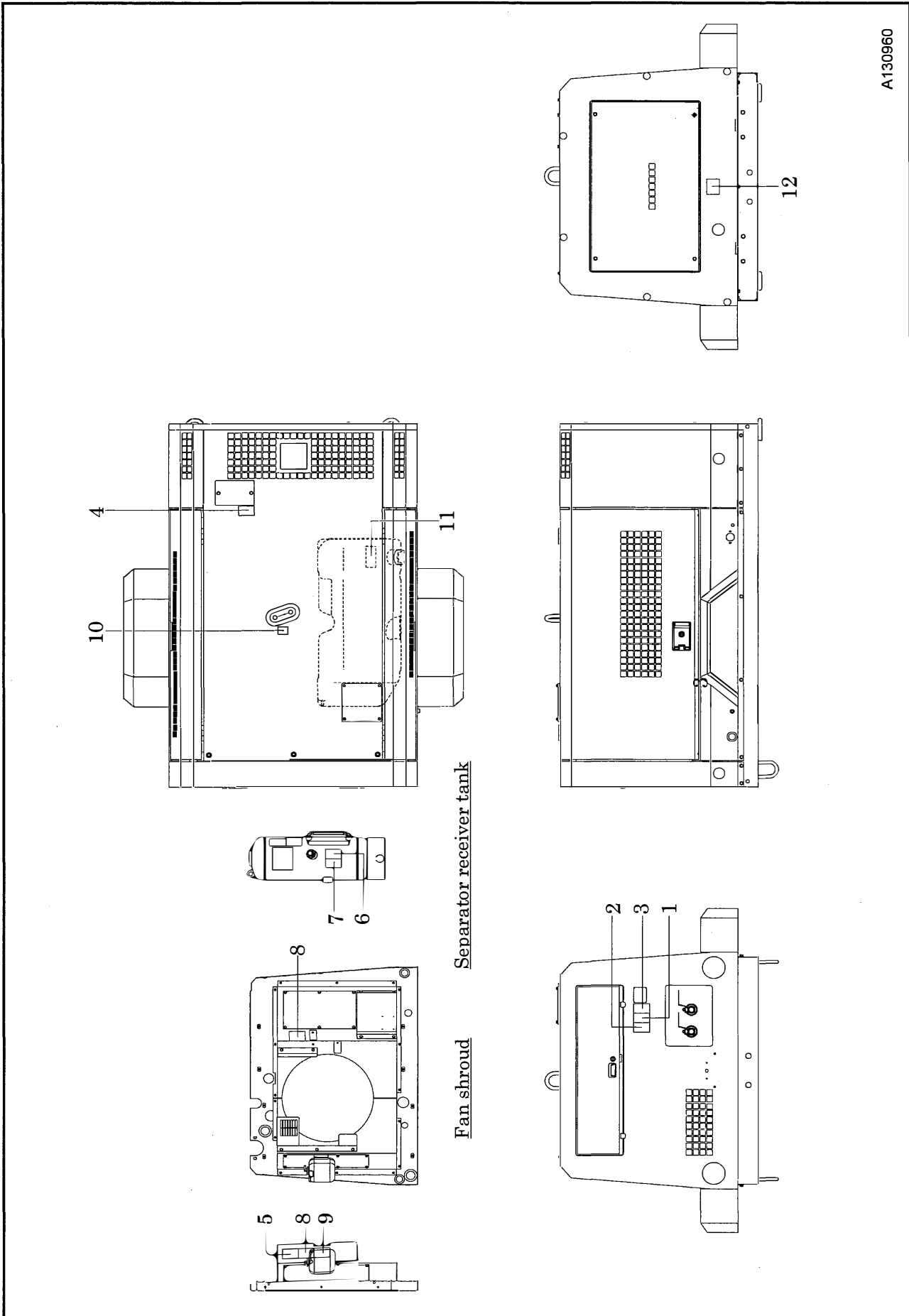

A130960

# MEMO

---

---

---

---

---

---

---

---

---

---

---

---

---

---

---

---

---

---

---

---

---

---

---

---

---

---

---

---

## 2.Part Names

### 2.1 Internal Components and Part Names

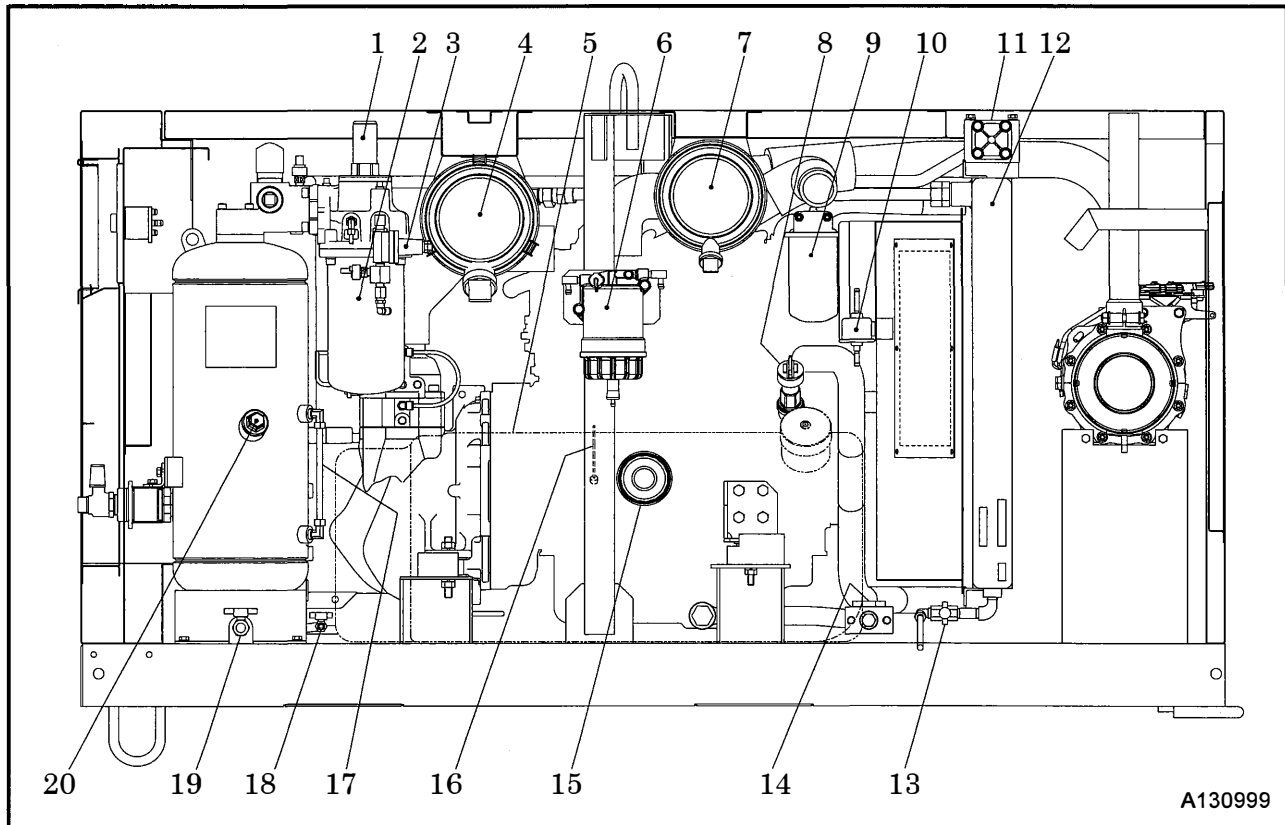

A130999

No.	Description	Function
1	Pressure control valve	For keeping the receiver tank pressure higher than 58psi(4bar) in the tank.
2	Oil separator	For separating oil mist mixed in compressed air.
3	Pressure regulator	For regulating intake air volume.
4	Air filter (For compressor air-end)	For filtering the dust floating in the air in the system. Equipment to filter the dust floating in the air suction.
5	Fuel tank	For storing diesel fuel oil.
6	Fuel pre filter	For filtering dust and foreign things mixed in fuel oil and also for separating water.
7	Air filter (For engine)	For filtering the dust floating in the air in the system. Equipment to filter the dust floating in the air suction.
8	Engine oil filler port	For supplying and replenishing engine oil to engine.
9	Fuel filter	For filtering dusts or foreign things in fuel in the system.
10	Air bleeding electromagnetic pump	For automatically bleeding air from fuel pipes.
11	By-pass valve	For keeping compressor oil at proper temperature.
12	Oil cooler	For cooling compressor oil circulating in the system.
13	Oil cooler drain valve	For draining compressor oil out of oil cooler and oil lines.
14	Engine oil drain valve	For draining engine oil for replacement of it and for maintenance.
15	Engine oil filter	For filtering engine oil.
16	Engine oil level gauge	For checking engine oil level.
17	Compressor oil level gauge	Scale for measuring compressor oil level.
18	Fuel tank drain valve	For draining condensate accumulated in fuel tank.
19	Separator receiver tank drain valve	From this portion where condensate is drained out of separator receiver tank.
20	Compressor oil filler port	For supplying and replenishing compressor oil.



## 2.Part Names

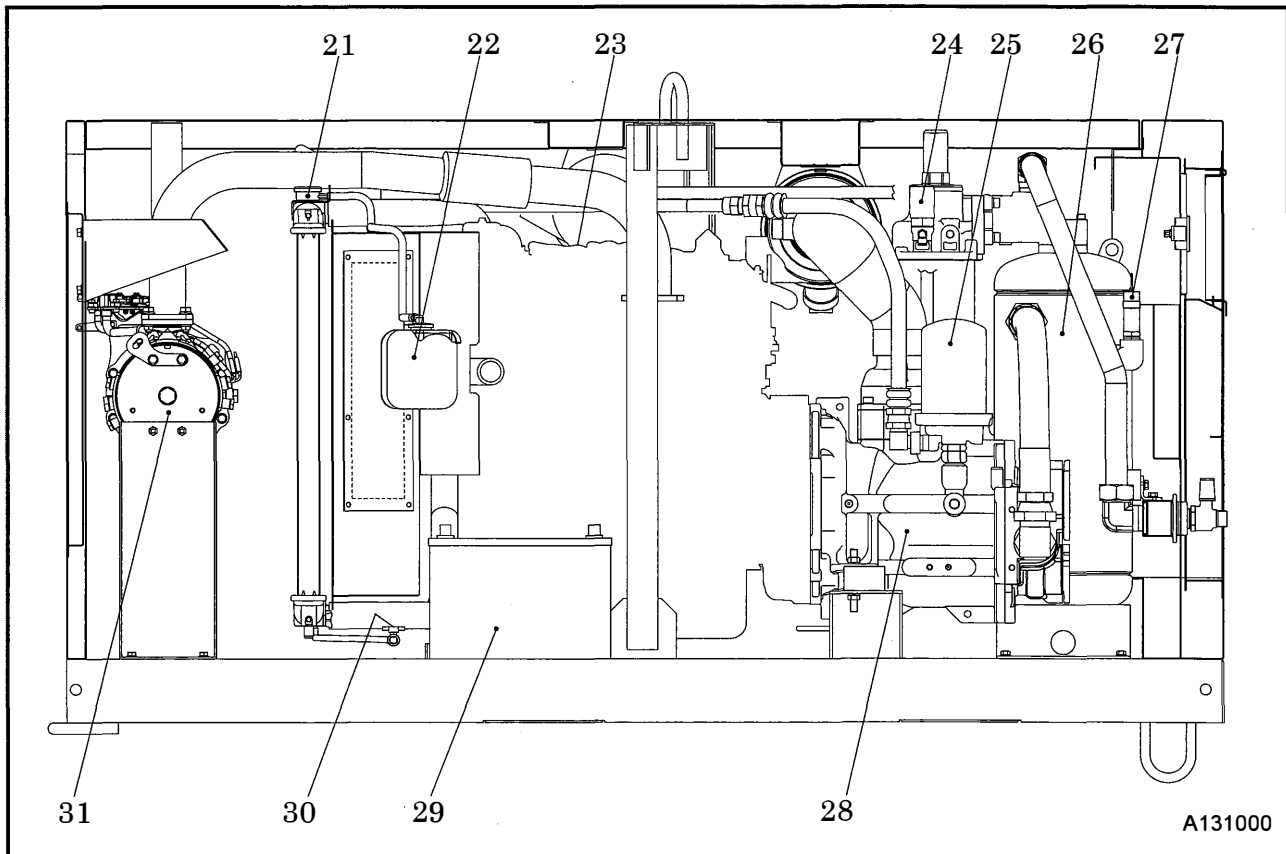

No.	Description	Function
21	Radiator	For cooling the coolant for engine because it is water-cooled.
22	Reserve tank	For checking engine cooling water level and for replenishing cooling water.
23	Engine	For driving the compressor.
24	Solenoid valve for starting unloader	For reducing load at start-up.
25	Compressor oil filter	For filtering compressor oil circulating in the system.
26	Separator receiver tank	For separating air and oil from compressed air in the system.
27	Safety valve	For releasing compressed air to the atmosphere when the pressure rises higher than the rated pressure.
28	Compressor air-end	For compressing air in the system.
29	Battery	For electrically starting engine.
30	Radiator drain valve	For draining engine coolant.
31	DPF (Diesel particulate filter)	Apparatus for removing harmful components contained in the exhaust gas

## 3. Installation

### 3.1 Transportation



#### *Transportation*

- When loading and unloading unit, be sure to use the lifting bail provided on the center of the unit top.
- Never get under the unit which is lifted up, because it is very dangerous.
- When unit is transferred or moved from working site, be sure to place it on truck bed, and fasten it by ropes at the front eye and rear stand. Also be sure to put a set of chocks to fix its wheels firmly on the truck bed.
- Never lift unit which is still in operation, or it could cause critical damage to each component or lead to serious accident.
- When unloading this machine, take care not to shock it by falling. It could lead to damaging the instruments, resulting in a serious accident.

#### 3.1.1 Lifting up

- ① Before lifting the unit up, make sure to check the lifting bail for any crack and loosened bolts.
- ② Connect the hook "1" of the crane or shackle with lifting bail "2" eye fitted at the top center of the unit, and make sure that there is no person standing around the unit. Then perform hoisting operation.
- ③ Select a truck or a crane with capacity sufficient for weight and size of the unit by referring to the values shown in Chapter 8 "Specifications" of the manual.

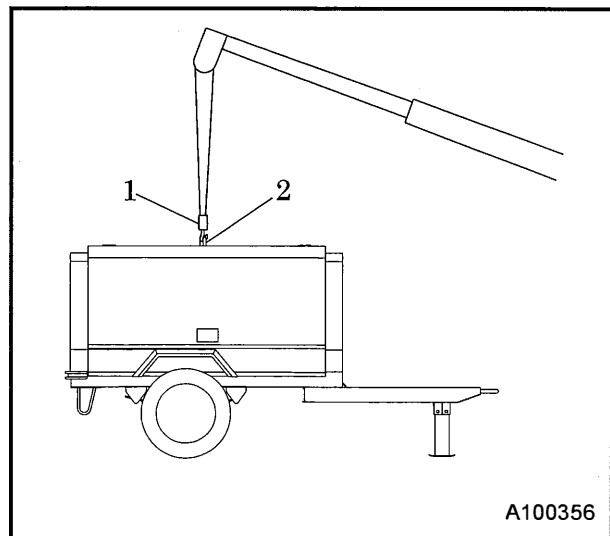

A100356

### 3.2 Towing the Unit



#### *Caution for towing machine*

- Before towing the machine, make sure to check and confirm that the following points have no problem.
  - Tire air pressure is proper.
  - Tire fixing nuts are not loose.
  - Tires are not worn nor damaged.
- Make sure that the end of the drawbar is so surely and firmly connected to the coupler of the towing vehicle that the disconnection may not occur while the machine is being towed.
- Make sure if there is no deform or damage on the drawing vehicle and the drawbar of the machine.
- Be sure to keep your hand or finger away from any part of the coupling device when coupling or uncoupling a drawing device to a draw bar.
- Be sure to drive the drawing vehicle safely, avoiding dangerous place or ground, if any.
- If you do not follow the above instructions, it could cause serious injury or big damage.

## 3. Installation

### 3.3 Installation

**⚠ WARNING**

- Exhaust gas from the engine is poisonous, and could cause death when inhaled.  
Avoid using the machine in an insufficiently ventilated building or tunnel.
- Do not position the exhaust gas outlet in direction of a person or a house.

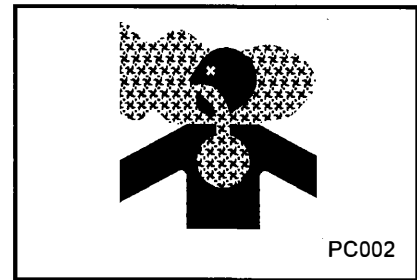

- The machine should be operated in following conditions:
  - **Ambient temperature** ..... **5°F to 104°F (-15°C ~ +40°C)**
  - **Humidity** ..... **Less than 90%**
  - **Altitude** ..... **Lower than 4,921ft above sea level**
- Install the machine in a place with good ventilation, lower temperature and with surroundings as dry as possible.
- If more than two machines are placed parallel in operation, keep enough distance so that exhaust air from one machine does not effect the other one.
- Also, a machine has to be installed in the environment where fresh air is always available.
- Keep enough space around the unit for inspection and maintenance access.

#### 3.3.1 Installation

**⚠ WARNING**

**Installation**

- The machine has to be parked horizontally on a level place.
- In case the machine has to be parked on a slope, place it across grade so that the machine does not tend to roll downhill.
- Following grades on a slope for the machine are recom- mended within 15° degrees.
- In case of trailer type, be sure to put one set of chocks "1" to the wheels.

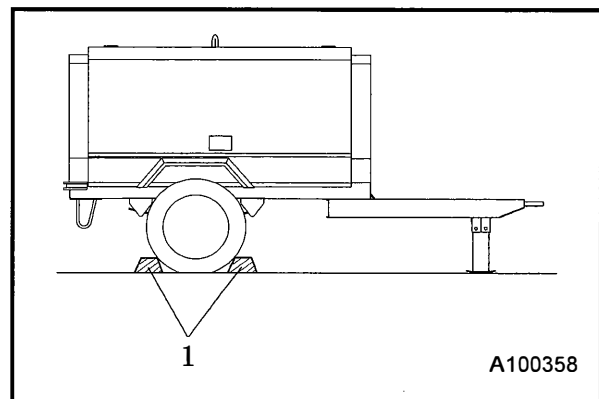

## 3. Installation

### 3.3.2 Service valve

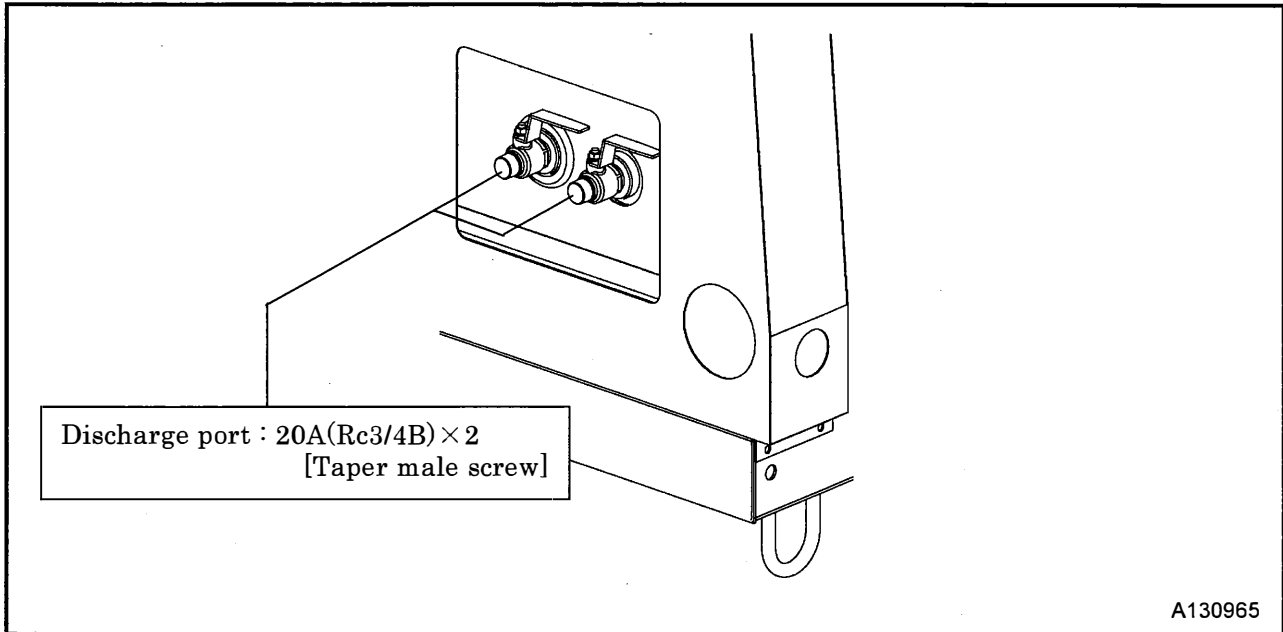

# 4. Operation

## 4.1 Instrument Panel

Each display of the operation panel is illustrated as follows.

Read and fully understand the explanations and be sure to operate safely:

**Error code switch**

When this switch is pushed on while lamp is blinking, it shows error code. When starter switch is placed to "STOP", displayed screen is reset.

For details of the blinking state (warning) and the illumination state (trouble) of failure codes, refer to 5.1.

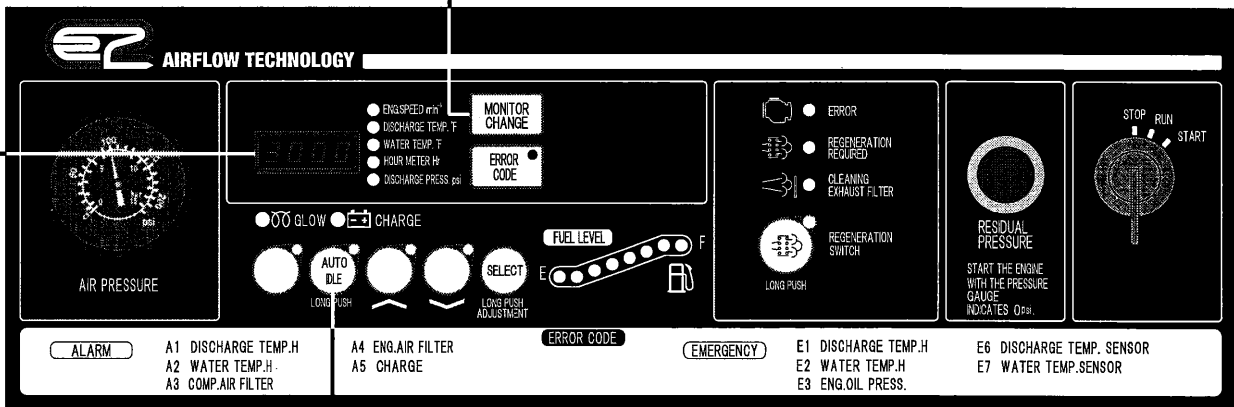

**Auto idle switch**

The switch is used for minimizing fuel consumption at no-load operation. (It functions when the lamp goes on.)

A130957

**Digital monitor**

When power is supplied, revolution speed (lamp lighting) is indicated.

Whenever indication selector switch is pushed every time, indication screen is changed by turns as shown above.

- [ENG.SPEED] (min<sup>-1</sup>)
- [DISCHARGE TEMP.] (°F)
- [WATER TEMP.] (°F)
- [HOUR METER] (Hr)
- [COMPRESSURE LOAD FACTOR] (%)
- [SERVICE PRESSURE] (PSI)

- In case the compressor load factor is more than 50%, "b - H" is indicated on screen.
- The indication of service pressure / the compressor load factor is displayed only at the time of purge driving.

## 4. Operation

### 4.2 Lubricant • Coolant • Fuel

#### 4.2.1 Engine oil

##### IMPORTANT

- Viscosity of engine oil greatly affects startability, performance, oil consumption of the engine, as well as wear of the moving parts. Choose appropriate oil based upon the table below according to the outside air temperature.

Ambient temperature range and oil viscosity (SAE)

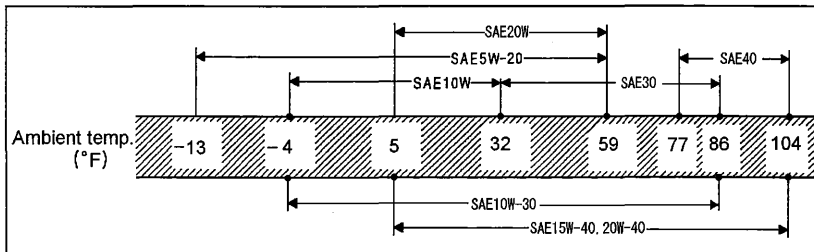

- Use engine oil recommended by us.

Classification	API service classification CJ-4
Viscosity	SAE 10W-30

- Be sure to use CJ-4 class engine oil or superior class. (Using engine oil with poor quality may shorten the life of the engine).
- When two or more different brands of oil are mixed, its performance can be deteriorated. Do not mix oils.
- When it is expected to be used for a long period at light load (less than 20% load), it is better to replace the oil with suitable oil.
- Follow the designated regulations to dispose of engine oil.
- \* **Unit is delivered ex. factory, filled with engine oil recommended by engine manufacturer.**

#### 4.2.2 Compressor oil

##### IMPORTANT

**Do not mix compressor oil**

- Be sure to use recommended oil listed below.

Maker and Brand of Recommended Oil

Maker	Brand
HULS	ANDEROL 3032
MOBIL	RARUS SHC 1024
TEXACO	SYN-STAR DE32

- Even continuous oil replenishment cannot improve its deteriorated condition. Be sure to change the oil completely at every scheduled interval.
- Do not mix it with other brand oil, or it will cause poor performance and shorten the life of the compressor oil. (But fresh compressor oil could accept a mixture of small amount of different brands.)
- Running the unit with old and deteriorated compressor oil will cause damage to bearings, or serious accident like ignition in a separator receiver tank. Be sure to change the oil completely at every scheduled interval.
- Follow the designated regulations to dispose of compressor oil.
- \* **Unit is delivered ex. factory, filled with "AIRMAN OIL LONG LIFE".**

## 4. Operation

### 4.2.3 Coolant

#### IMPORTANT

#### *Quality of coolant and antifreeze*

- Use soft water of good quality such as tap water for coolant.
- When water with dirt, sand, and/or dust contained, or hard water such as well water (ground water) is used, this will cause deposits inside radiator or on cylinder head, and will cause engine overheat due to poor flow of coolant.
- When the unit is used in a cold region and possible freezing is expected, it is recommended to use LLC (Antifreeze) for the coolant.
- Adjust mixing ratio of LLC (Antifreeze) with water according to the temperature.
- Use LLC (Antifreeze) within the range of its mixing ratio between 35 and 60%.
- If LLC (Antifreeze) in the water exceeds more than 60%, it may decrease its antifreezing effect. (Upon delivery from the works, LLC density is 55%)
- Use LLC (anti-freeze) which conforms to one of such standards : SAE JB13, SAE J1034 and ASTM D3306.
- **Follow the designated regulations to dispose of LLC (Antifreeze).**

### 4.2.4 Fuel

#### IMPORTANT

#### *Choose appropriate fuel*

- Do not use such diesel fuel having higher sulfur content above 0.0015%(15 ppm)
- Use ultra-low sulfur diesel fuel only for diesel engine.
- Use such diesel fuel which conforms to either standard EN590 or ASTM D975.
- Do not use kerosene. And never use fuel mixed with kerosene.
- **Follow the designated regulations to dispose of fuel.**

#### CAUTION

- Fuel for diesel engine must have the following specific characteristics.
  - It must be free from even minute dust particles in it.  
(Do not use such diesel fuel which has been long stored in a oil drum.)
  - It must have optimum viscosity.
  - It must have high cetane number.
  - It must have high fluidity even at low temperature.
  - Carbon residue content in fuel must be a little.
  - It must not contain zinc and NA (sodium).

## 4. Operation

### 4.3 Check before starting unit



**Check before starting unit**

- Be sure to check the unit before operation.  
When any abnormality is found, be sure to repair it before restarting the unit.
- Be sure to make daily checks before operation. If the unit is operated without prior check and without noticing its abnormality, such operation could cause seizure of components or may even cause fire.

#### 4.3.1 Check engine oil level

- Unit should be on level before checking oil level.
- When you check oil level after you have once started operation, wait 10 to 20 minutes after stopping engine, before checking the oil level.

<Procedure>

- ① Pull out the oil level gauge "1", and wipe it with a clean cloth.
  - ② Then, re-insert the oil level gauge "1" fully and pull it out again. If the oil level gauge "1" shows the oil level between LOW and HIGH, it is normal.
  - ③ When the oil level is below its LOW, add engine oil from oil filler port "2" .
- While checking oil level, check also for contamination. If the oil is found dirty, contaminated or should it be changed according to the periodic inspection list, change the oil. **(See 6.5.1)**
  - Excessive engine oil supply could cause engine output degradation. Therefore, never fill more than the HIGH level.

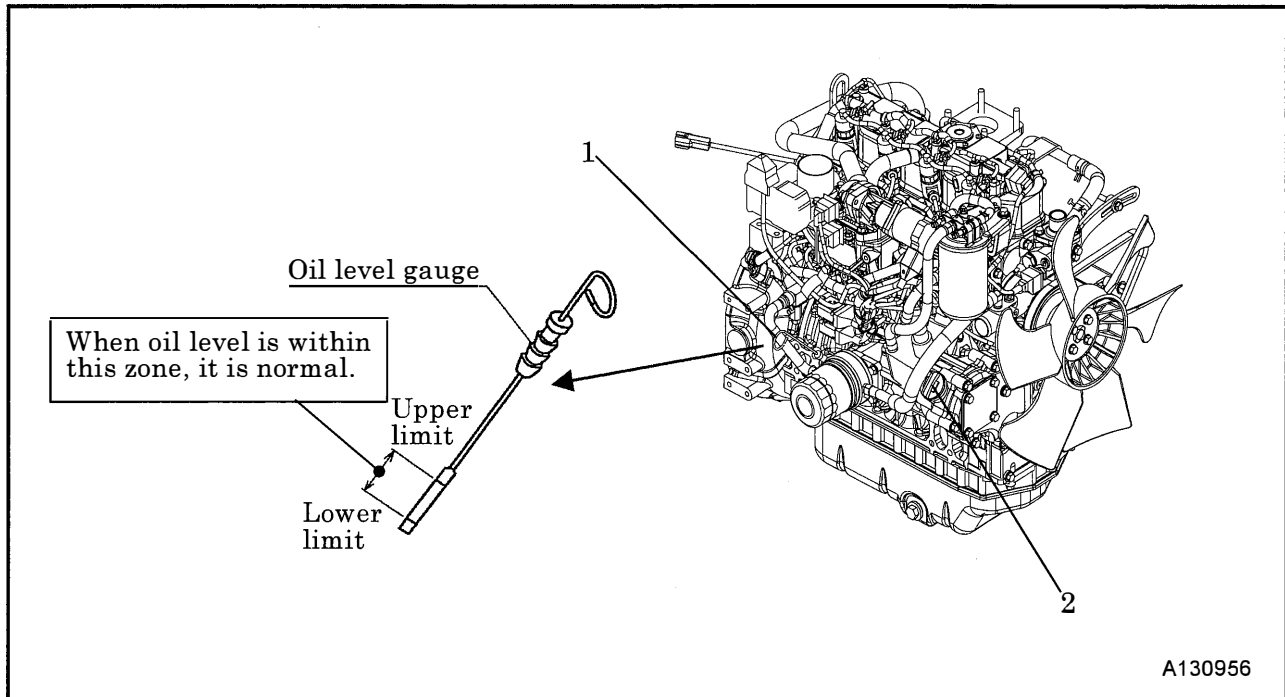



## 4. Operation

### 4.3.2 Check coolant level

#### CAUTION

- Be sure to stop the machine and allow time to cool. Then loosen the radiator cap one notch. After the coolant water is sufficiently cooled and the inner pressure is released, take the cap off. If this procedure is neglected, the inner pressure can blow off the cap. Steam jetting out of the radiator could result in causing scalding. Follow this procedure under all circumstances.

#### Taking off the radiator cap

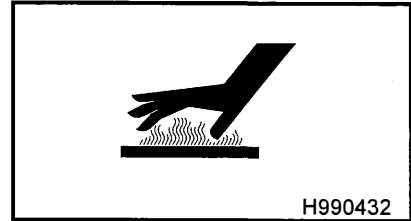

H990432

#### IMPORTANT

- Do not continue operation at low coolant level. Air bubble is mixed into radiator, and it causes damage to the radiator.
- Check the coolant level in the reserve tank. If it is lower than the limit, open the cap and replenish the coolant. (Level must be kept above LOW mark.)
- When there is a little water or no water in the reserve tank, remove the radiator cap and make sure to check the water level. Then supply coolant to the radiator and also the reserve tank, if necessary. (See 6.5.16)

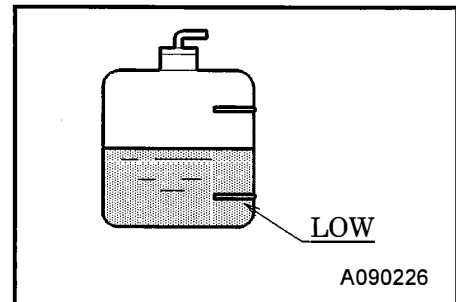

A090226

### 4.3.3 Check compressor oil level

#### WARNING

- When you refill the separator receiver tank with compressor oil, stop the engine, and make sure that the pressure gauge indicates 0psi (0bar) and there is no residual pressure in it, and then gradually loosen the oil filler cap for refilling oil.
- Should any residual pressure be left in the separator receiver tank, hot compressed air and hot compressor oil jetting out could cause burning or serious injury to persons nearby.

#### Refilling of compressor oil

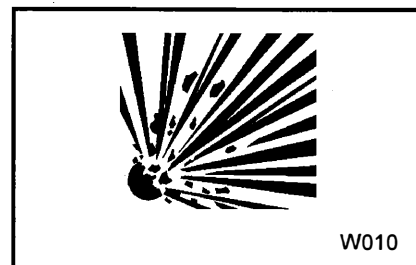

W010

- Place the machine on level ground when checking the oil level.
- After checking and confirming that the residual pressure in separator receiver tank is 0psi (0bar), replenish the tank with compressor oil at higher level than the middle between the upper limit and lower limit of oil level gauge when the machine is on. (See 6.5.6)  
(Oil level drops when starting operation.)
- ※ Supply of excessive oil can cause deterioration of oil separation performance and the like. Never supply oil at a higher level than the upper level of oil level gauge.

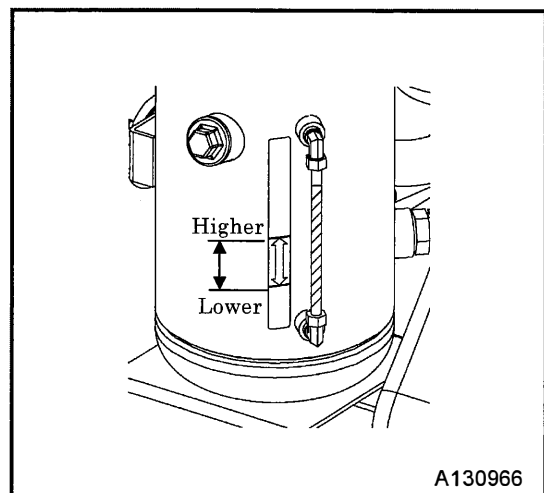

A130966

## 4. Operation

### 4.3.4 Drain separator receiver tank

#### WARNING

- After stopping the engine, confirm that the pressure gauge indicates 0psi (0bar) and there is no residual pressure in it, then open the drain valve gradually to drain the compressor oil.
- Note residual pressure in the receiver tank could force both extremely hot compressed air and oil to jet out and you may be scalded or seriously injured.

#### Draining of Separator receiver tank

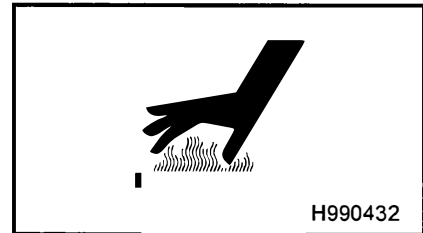

- Gradually opening the drain valve “2” fitted under the separator receiver tank “1” as shown in the fig, drain the condensate.
- Be careful not to fully open the drain valve “2” . Otherwise, much oil may be lost.
- After draining the oil completely, close the drain valve “2” firmly.
- Drain the condensate in container “3” , and then dispose of condensate according to the designated regulations.
- Touch the fluid and check its viscosity to determine whether it is condensate or compressor oil, and when it is difficult to distinguish between the two.

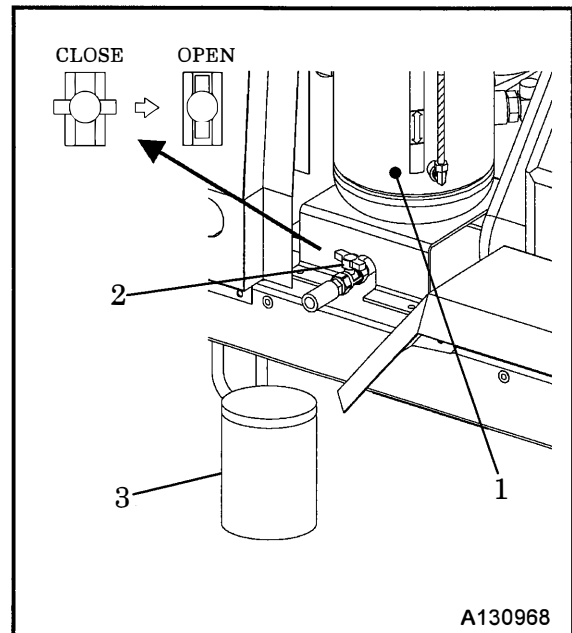

### 4.3.5 Check fuel

- Before starting operation, make sure to check the level of residual fuel so that fuel shortage during operation can be avoided.
- Drain condensate accumulated at the bottom of fuel tank whenever necessary.

#### CAUTION

- Do not, under any circumstance, bring lit cigarettes and/or matches to the fuel.
- The fuel is extremely flammable and dangerous. Be careful of fire because it is very likely to catch fire.
- Refuel only after stopping the engine, and never leave open fuel can near the machine. Do not spill. It could cause a fire. When it is spilt, wipe it up completely.
- Refilling fuel tank should be done in an outdoor well-ventilated place.
- **Do not fill fuel oil up to the cap level. When fuel tank is filled up to the cap level, fuel oil will be overfilled due to volume expansion caused by rise of ambient temperature. Further, fuel will be possibly spilled from fuel tank due to vibration caused during movement and/or transportation of machine.**

#### Fire prevention



## 4. Operation

### 4.3.6 Drain fuel tank

- Opening the drain valve “2” fitted under the fuel tank “1”, drain the condensate from the tank.
- When completely drained, firmly close the drain valve “2” .
- Drain the condensate in container, and then dispose of condensate according to the designated regulations.

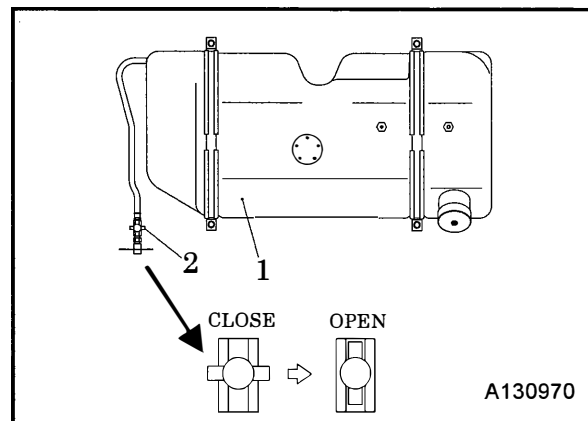

### 4.3.7 Check Pre-filter for condensate

When red float “2” under element “1” in Pre- filter is raised up to upper level, drain water.

<Draining procedure>

- ① Turn fuel selector valve “3” to “OFF” position.
  - ② Loosen the drain valve “4” and drain out condensed water inside.
  - ③ Make sure to tighten the drain valve “4” securely, after draining the condensate.
- Drain the condensate in container, and then dispose of condensate according to the designated regulations.

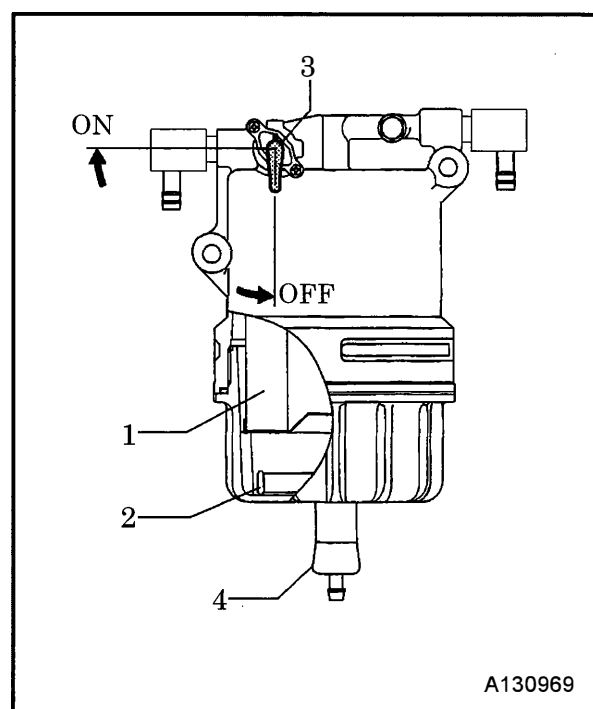

### 4.3.8 Check wiring of each part

Check each wiring for any loose connection, damage to insulating sheathed portion, disconnection, and short-circuit.

### 4.3.9 Check piping of each part

Check each piping for any loose connection and also check each hose and pipe for any tear and leaks.

### 4.3.10 Periodical Inspection of Machine Insides

- Periodically check the inside of the generator for dusts (rubbishes) and flammables. When any flammables such as chips of wood, dead leaves (dry leaves) and waste paper are left near heated exhaust muffler and heated exhaust pipe, all of them should be eliminated.

## 4. Operation

### 4.3.11 Check belt tension

#### IMPORTANT

- Too tight belt tension could damage shaft and shorten bearing life. Too loose belt tension may result in damaging belt earlier and machine components due to overheat.
- Follow the procedure below to adjust tension of fan belt and belt for alternator.
- Adjust the tension by gradually loosening the fastening bolt of the alternator.

#### <Procedure>

- ① Visually check if there are any cracks or tears in the belt.
- ② Adjust the belt tension by loosening the fixing bolt "1" of the alternator so that the belt can deflect 0.39 to 0.55 in. (10 to 14mm) when pressed at the center of the belt with approx. 22lbf (98N) force.
- ③ Be careful not to leave any grease or LLC on a belt while changing it. If any such material is left, wipe it off completely.

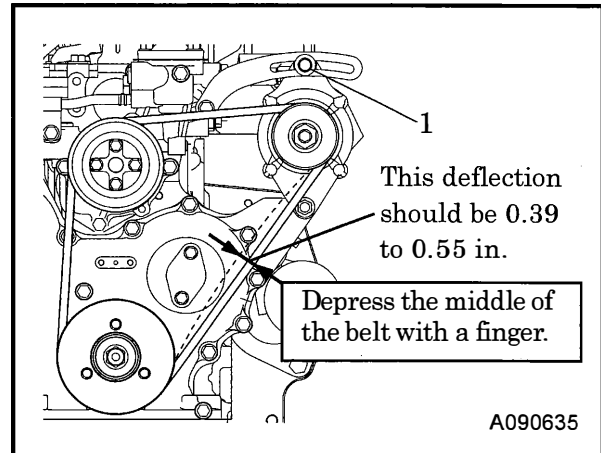

### 4.4 Operation

#### CAUTION

**Operation with compressed air supply port opened is prohibited**

- Do not operate the machine with service valves and relief valve open unless air hoses and/or pipes are connected. High-pressurized air blows out and its air pressure could cause injury to the people nearby.
- When the machine has to be unavoidably temporarily operated with its port open, be sure to mount a silencer to reduce noise and wear protective materials such as earplugs to prevent damage to hearing.

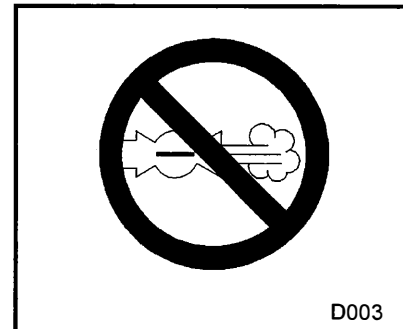

D003

#### WARNING

- Keep the door closed and locked while running the unit.
- When the door has to be opened, be careful not to touch portions that are rotating or very hot. Careless touch may cause serious injury.
- Pull the handle forward to open the door.
- Be sure to close the door tightly so that its latch is firmly caught.



PK0028

# 4.Operation

## 4.4.1 Procedure to start the unit

### IMPORTANT

### Be sure to warm-up

- Be sure to let unit warm-up after starting for smooth operation of the engine and the compressor. Do not operate the engine at full load immediately after it starts up. This will shorten the equipment life.
- During the warm-up operation, examine the different parts of the equipment for any looseness, leakage of water, oil, fuel, and other irregularities. Also, make sure that monitor lamps are off.

#### <Procedure>

- ① Ascertain that the discharge air pressure gauge indicates 0 psi
- ② Close fully service valve.
- ③ Turn the starter switch “1” to “RUN” position, and the glow lamp “2” goes on.
- ④ When the glow lamp “2” gone out, turn the starter switch “1” to “START” position for starting. Perform starting operation of starter switch within 15 seconds. Further, wait longer than two minutes before next starting operation. It could cause overheating to the starter motor and it could damage it.
- If there is a residual pressure in the separator receiver tank, residual pressure lamp starting “3” lights by turning the position of the “RUN” the starter switch, the starter does not rotate. Please make sure that it is the “Opsi” residual pressure remains always.

According to engine cooling water temperature, the times in the following table are required.

Engine coolant temperature	Required time for preheating	Required time for starting unloader operation
Higher than 50°F	1 sec	30 sec
Lower than 50°F	20 sec	Shorter time either 120 seconds or the time when engine coolant temperature becomes higher than 50°F.

- ⑤ Once the engine has started up, leave it running to warm-up for 5 minutes. The discharge air pressure gauge “4” in this condition ranges from 44 to 102 psi (3 to 7 bar).
- ⑥ After finishing warming up operation, open the service valve provided at the outlet of compressed air and start service job.

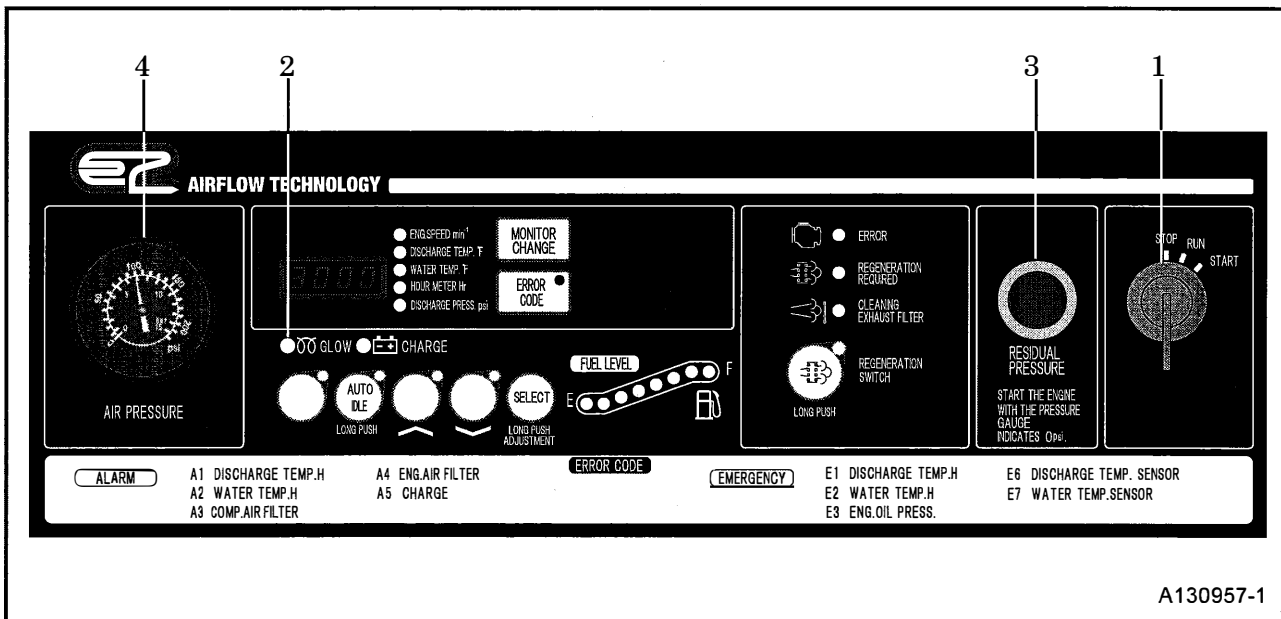

## 4.Operation

### 4.4.2 Operating procedures when engine fails to start up on first attempt

- When the engine fails to start up even after performing the startup procedures ① to ④, do not keep the starter running, but set the starter switch back to “STOP” and wait about more than 2 minutes. Then, repeat the startup procedure once again.
- If the repeated procedure does not allow the engine to run, the following causes are suspected. Therefore, check the following:
  - No fuel
  - Clogging of fuel filter
  - Discharge of battery (Low cranking speed)
  - Ambient temperature is too low.

### 4.4.3 How to start the unit at low temperature

**IMPORTANT*****Operation under Cold Weather Conditions below 23°F (-5°C)***

- Use SAE10W-30 (CJ-4) for the engine oil.
- Use LLC (antifreeze). Use correct amount to provide freeze protection, according to the ambient temperature.
  - In accordance with 4.2.3, use LLC (antifreeze) mixed according to the mixing ratio for ambient temperature.
- Battery should always be kept fully charged.

When it is difficult to start engine in cold weather, take the following measures.

<Procedure>

- ① Fully close the service valves
- ② Start engine by taking normal starting procedure.

[Caution]

- When operating the unit in a low temperature, change engine oil, compressor oil, LLC and diesel fuel according to the ambient temperature.







## 4. Operation

### 4.4.4 Gauge Indication while operating

**IMPORTANT**

- Minimum discharge air pressure is 58psi (4bar) during operation.
- Continuing equipment operation at a lower pressure than the above pressure may cause overheating, since it affects the separation of lubricating oil inside the oil separator and reduces the oil flow to the compressor air-end, resulting in temperature rise.

- Be sure to check at times to see if gauges or each component of the unit are properly working, or if there is any air-leak, oil-leak, water-leak or fuel-leak etc.
- During normal operation, each indication of instruments is shown in the table below. Refer to the table for daily checks.
- The above table gives standard values. They may vary slightly depending on the operating conditions and other factors.

Protection device		Indicator lamp					
		GLOW	CHARGE	DPF REGENERATION REQUIRED	DURING DPF REGENERATION	ENGINE ERROR	AUTO IDLE
Monitor							AUTO IDLE
Starting	Starter switch set to "RUN" position	● OFF ※1	 ON	● OFF	● OFF	● OFF ※2	● OFF
In operation		● OFF					

※1 This lamp will be OFF in 0 to 20 seconds, (varying upon ambient temperature.)

※2 This lamp will be OFF in about 2 seconds.

Discharge pressure gauge		
In operation	Full load	58 to 100 psi (4 to 6.9 bar)
	No load (Unload)	116 to 131 psi (8 to 9 bar)
	At purge control (AUTO IDLE)	36 to 58 psi (2.5 to 4bar)



# 4. Operation

## 4.5 Capacity Control Device

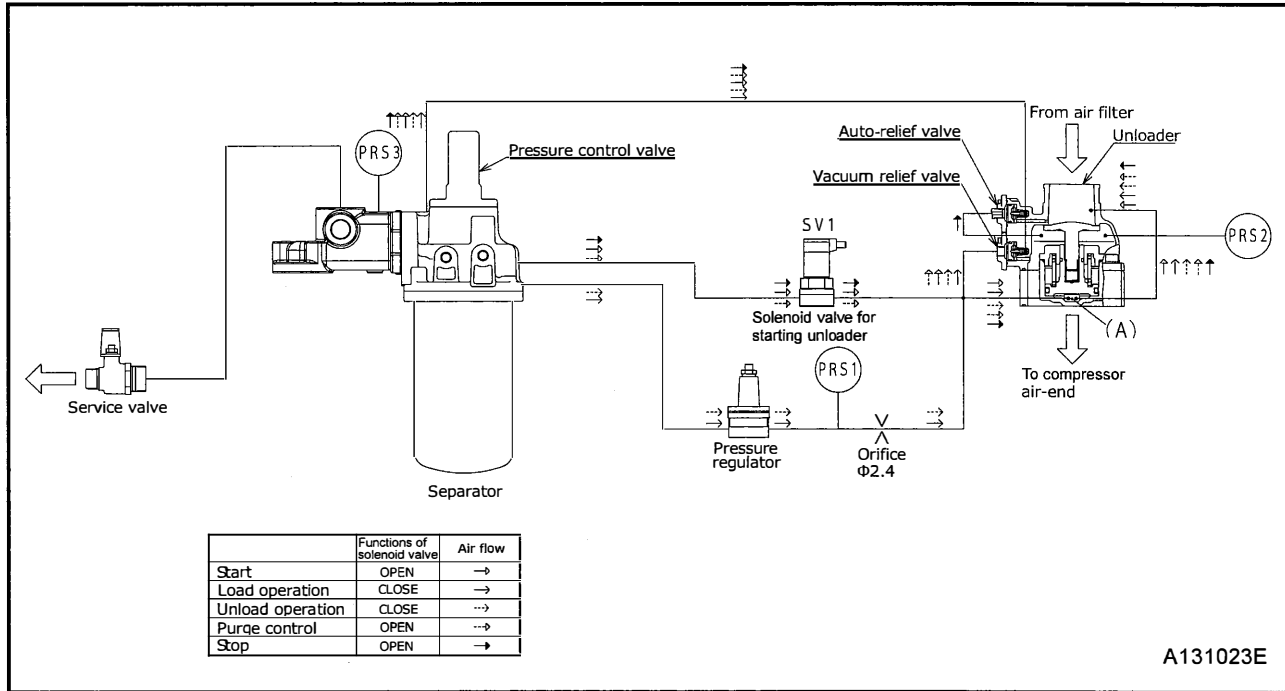

Step	Response
Start	Compressed air flows into unloader chamber (A) because solenoid valve for purge control SV1 is opened at start-up. The pressure in chamber (A) rises soon to close unloader valve (A) fully and accordingly it can reduce the load at start-up.
Load operation	After starting, SV1 is closed after automatic unloaded operation, and the air volume which is sent to chamber (A) increases and decreases according to the rise and drop of the discharge air pressure and consequently the opening width of the unloader valve is changed. Further, engine revolution (RPM) is changed by the pressure which PRS1 detects, and it steplessly controls the air volume in the range from 0 to 100%.
Suction port closing unload operation	When compressed air pressure exceeds the rated pressure with reduction of air consumption, PRS1 detects the pressure and it reduces engine speed (rpm) in proportion to the pressure rise, and it closes unloader valve at the same time. When compressor air-end becomes vacuum during unload operation, vacuum noise is caused. To prevent this noise, it opens vacuum relief valve by detection of secondary pressure of pressure regulator. Thus high vacuum condition of compressor air-end is prevented.
Purge control unload operation	When the certain set time (it can be changed.) has passed at lower pressure than the set negative pressure, detecting the negative pressure inside the compressor air end with a pressure sensor PRS2, solenoid valve SV1 opens and it closes unloader valve. At the same time, it functions to relieve the compressed air from separator receiver tank to the atmosphere and thus it lowers the pressure. Thus the compressor power is saved. When air consumption increases, and the pressure used for load drops below the set pressure, pressure sensor PRS3 detects it and it disengages the purge control (SV1 closes) to start full load operation.
Stop	When stopping operation, it opens Auto relief valve to relieve the compressed air in separator receiver tank to atmosphere, detecting the pressure inside compressor air-end.



## 4.Operation

### 4.5.1 AUTO IDLE control (Purge control)

This model is equipped with auto idle control operation mode. This operation mode is recommendable for such use: not so much air consumption is required and it is used continuously and also power consumption under unloaded operation is required to be saved. Use this mode, depending upon the need and demand. For the selection of this mode, switch on “AUTO IDLE” on the operation panel. Select this operation mode freely, according to required air consumption.

<Procedure>

- ① During operation, long push on the switch “1” “AUTO IDLE”.
- ② Then the indicator lamp auto idle “2” goes on.
- ③ In order to stop this operation mode, push again auto idle switch “1” and then the lamp “2” goes out to disengage this purge control.

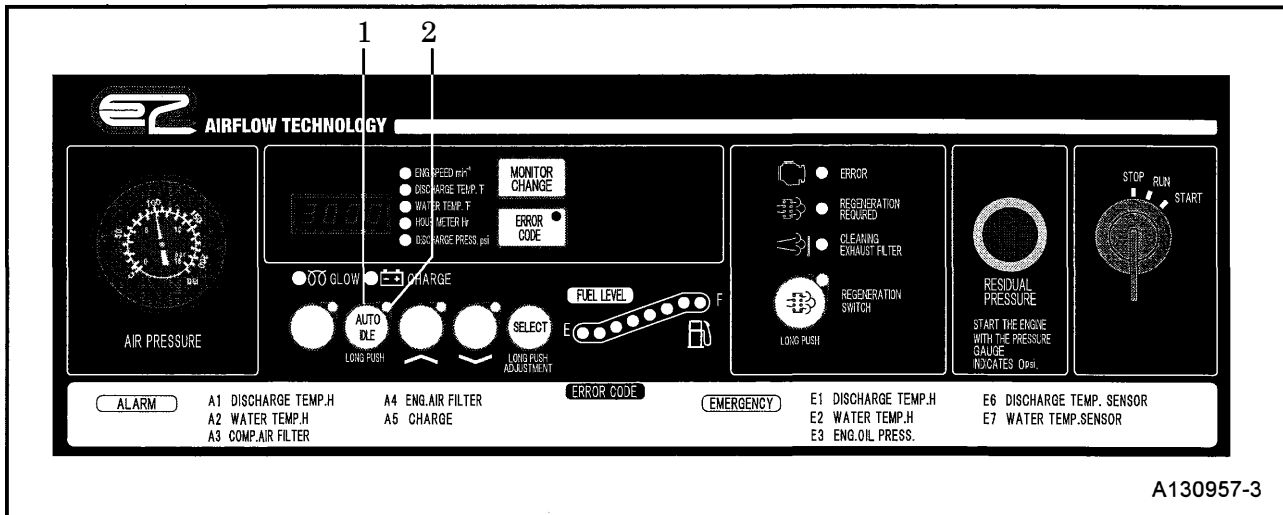

A130957-3

### [Function of auto idle control (Purge control)]

Function	Conditions of auto idle lamp
① First engine speed drops to the minimum speed by pressure regulator, owing to reduction of air consumption. Later the air consumption is reduced further, the unloader valve gradually closes and intake negative pressure increases. In this stage, the pressure sensor detects the intake negative pressure. Then when the intake negative pressure becomes higher than the set pressure, the “AUTO IDLE” lamp flickers at short intervals.	Lamp flickers at short intervals.
② When this condition continues for a certain time, the solenoid valve functions to start purge mode operation. Consequently, the pressure inside separator receiver tank drops and reduces the power of compressor air end. In this stage, the lamp “AUTO IDLE” flickers at longer intervals.	Lamp flickers at longer intervals.
③ Next, when the pressure for load down to the purge releasing pressure owing to the increase of air consumption, the solenoid valve operation gets “OFF” and it is transferred to normal operation. In this stage, the lamp “AUTO IDLE” goes on.	Lamp goes on.

## 4. Operation

---

### 4.6 Stopping

<Procedure>

- ① Close the service valve completely and operate the machine about 5 minutes, until it cools down.
- ② Turn the starter switch to “STOP” position to stop the engine.
- ③ Remove the key from the compressor every time when you stop the engine. Keep the key and be careful not to lose it.
- Unless all the service valve are fully closed upon stopping operation, the compressed air will be sent in reverse direction in the hoses (pipes) connected to air tools and relieved to atmosphere continuously through the auto-relief valve. Further, when re-starting operation next time, compressed air will be jetted out through service valves.

### 4.7 Air bleeding in fuel line

Should the machine stop due to fuel shortage, perform air bleeding according to the following steps.

<Procedure>

- ① Replenish fuel.
- ② When starter switch is turned to “RUN” position, electromagnet pump starts to automatically bleed air in fuel line.
- ③ Air bleeding is completed about 1 minute.

## 4. Operation

### 4.8 DPF regeneration

#### WARNING

- During DPF regeneration operation, exhaust gas of high temperature is discharged. Check and confirm that there is no person nor flammables near by. It could cause scalding to person and fire.
- During regeneration operation, take care of carbon monoxide poisoning in closed space.

- When regeneration control is begun and finished, noise of engine air intake throttle and EGR opening width adjustment is sometimes caused. But this phenomena is not abnormal.
- The smell of the exhaust gas caused during regeneration operation is different from that of diesel fuel used in the past.

#### 4.8.1 Passive Regeneration

- Soot collected in the DPF is burnt automatically because of high temperature during normal operation under heavy load application.

#### 4.8.2 Active Regeneration

- In the operation under light load application or no load, it turns into active regeneration because engine exhaust temperature is not enough high to burn the soot collected in the DPF.
- During automatic regeneration mode operation, it is possible to continue servicing job.

<Active regeneration mode>

- ① Cleaning exhaust filter lamp "1" is ON
- ② This regeneration process will last for about 30 minutes. (※1)
- ③ The lamp will be OFF when the regeneration is completed.

※1 Time required for regeneration depends on load factor and ambient temperature.

#### CAUTION

- Do not stop engine during automatic regeneration operation, except for unavoidable conditions.

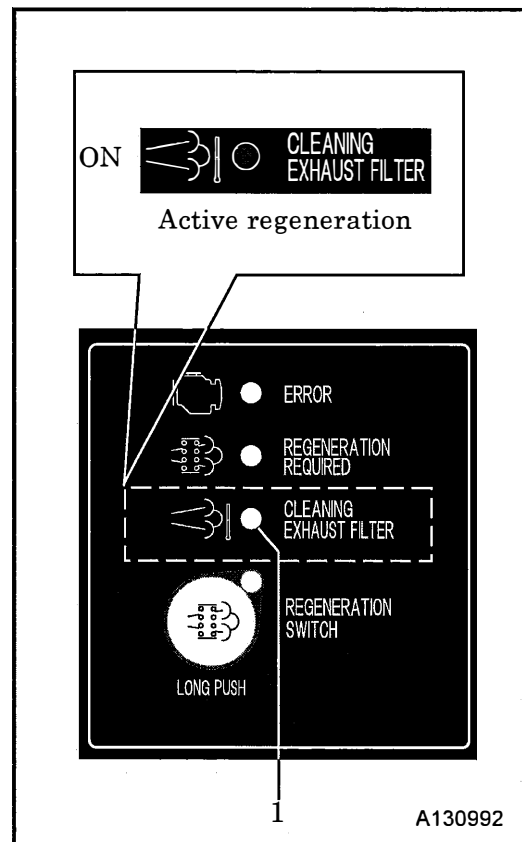

A130992

## 4. Operation

### 4.8.3 Manual Regeneration

- Except in unavoidable case, during automatic regeneration operation, do not stop engine. Especially when ambient temperature is very low and in almost no-load operation, incomplete soot combustion occurs. If operated continuously in the same conditions, regeneration required lamp goes on soon. In this case, take necessary procedure for enforced regeneration operation according to the following steps.

#### < Manual Regeneration Procedure >

- ① REGENERATION REQUIRED lamp "1" and ERROR lamp "4" go on. At the same time, REGENERATION SWITCH lamp "5" flashes. And also engine speed automatically changes to 1,350min<sup>-1</sup>.
  - ② Keep pressing REGENERATION SWITCH "3" longer than 3 seconds.
  - ③ REGENERATION REQUIRED lamp lights off and CLEANING EXHAUST FILTER lamp "2" goes on. Then REGENERATION SWITCH lamp "5" changes to lighting on instead of flashing and at the same time it automatically starts purge operation.
  - ④ Engine speed gradually increases up to approximately 2,200min<sup>-1</sup>.
  - ⑤ Under this state, manual regeneration operation is performed about 30 minutes.(※2)
  - ⑥ All lamps go off and manual regeneration operation comes to end, and it returns to normal engine speed and normal operation starts.
- ※2 Time of regeneration varies upon the ambient temperature.

- When continuing operation about ten hours without conducting manual regeneration even while REGENERATION REQUIRED lamp "1" is lighting, it will be impossible to conduct manual regeneration and it leads to low idling operation only. In this case, it becomes necessary to clean DPF (Diesel particulate filter). Please contact our nearest dealer.

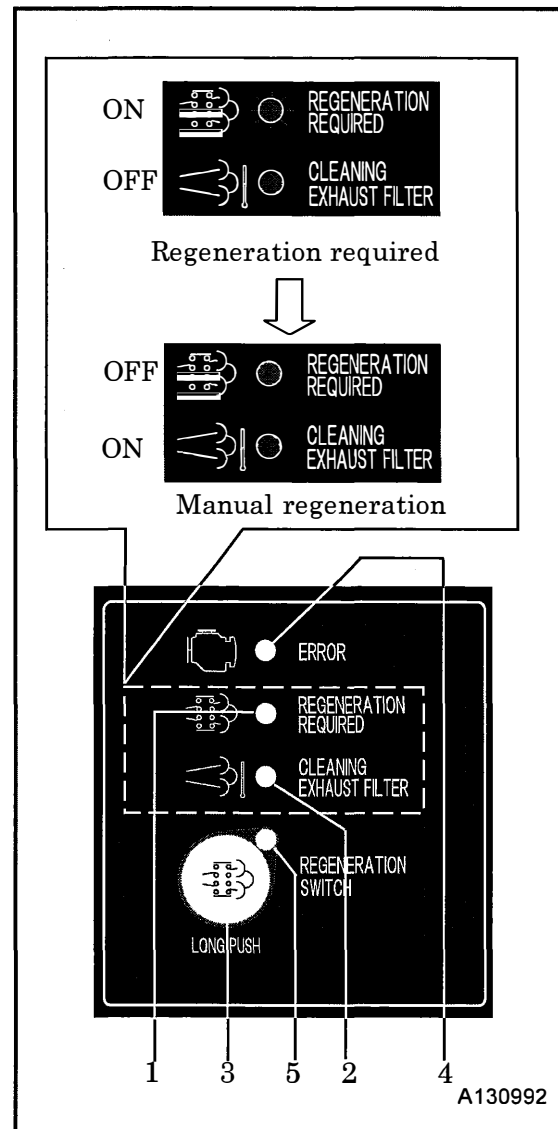

#### IMPORTANT

- When DPF regeneration lamp goes on, take immediate specified action to conduct manual regeneration. If it is continuously operated without manual regeneration, excessive soot will accumulate and it could damage DPF due to abnormal burning, and it could cause a fire.



#### CAUTION

- Do not stop engine during enforced regeneration operation, except for unavoidable conditions.

## 5 Failure cause and measures

### 5.1 Indicator lamp and Warning / Emergency display

**[Indicator lamp]** Turn the starter switch to “RUN” position. Then the lamp goes on.

Item	Contents	Measures	Monitor
GLOW	Press. starter switch “GLOW” and the lamp goes on and after preheating is finished, the lamp will be off.	—	
CHARGE	Lamp goes on when alternator is not charging.	Check wiring. Check alternator.	

**[Warning Display]** This displays such trouble of less importance when it occurs during operation, but the unit continues operating.

When any abnormality happens, a trouble code lamp flickers. In this time when trouble code switch is pressed, a failure code will be displayed.

Item	Failure code	Contents	Measures
DISCHARGE TEMP.H	A1	Lamp flickers when the air temperature at the outlet of the air-end reaches 239°F (115°C).	See “Troubleshooting”
WATER TEMP.H	A2	Lamp flickers when coolant temperature reaches 221°F(105°C).	
COMP.AIR FILTER	A3	When the air filter gets clogged and suction resistance increases, lamp comes on. [Actuating resistance: 6.2kPa or more]	Clean or replace
ENG. AIR FILTER	A4		
CHARGE	A5	Belt loosened and/or cut Faulty generation of alternator	See “Troubleshooting”

**[Emergency Display]** When any trouble takes place during operation, this displays and it stops as an emergency stop.

When any abnormality happens, a trouble code lamp flickers. In this time when trouble code switch is pressed, a failure code will be displayed.

Item	Failure code	Contents	Measures
DISCHARGE TEMP. H	E1	Lamp displays when the air temperature at the outlet of the air-end reaches 248°F (120°C).	See “Troubleshooting”
WATER TEMP.H	E2	Lamp displays when coolant temperature reaches 230°F(110°C).	
ENG. OIL PRESS.	E3	Lamp goes on when engine oil pressure drops. [The function pressure is below 7.3psi(0.5bar).]	
DISCHARGE AIR TEMP. SENSOR DISCONNECTION	E6	It is displayed when air temperature sensor at the outlet port of compressor air end is disconnected.	
COOLANT TEMP. SENSOR DISCONNECTION	E7	It is displayed when engine coolant temperature sensor is disconnected.	

## 5 Failure cause and measures

### 5.2 Troubleshooting

- Should any trouble occur during operation, do not leave it. Investigate the cause and take appropriate measures.
- Read the manual carefully and fully understand what to do in case of trouble.
- The better you understand the construction and function of the unit, the faster you can find a problem and solution.
- This chapter describes the state, cause and countermeasures of important troubles in detail:

Symptom	Cause	Countermeasures
Low starter revolution speed.	(1) Battery malfunction.	Check battery → Charge, change
Starter rotates but engine does not start.	(1) Fuel filter clogging. (2) Fuel pre-filter clogging. (3) No diesel fuel oil. (4) Air mixing in fuel pipings. (5) Failure of the engine stop solenoid.	Disassemble, clean, and change Disassemble, clean, and change Replenish fuel Bleed air Call your nearest dealer
Discharge air pressure does not reach 100psi(6.9bar).	(1) Pressure regulator insufficient adjustment. (2) Pressure regulator trouble.	Re-adjust (fasten) Change
Engine does not reach its maximum speed.	(1) Failure of the engine controller (2) Unloader orifice clogging. (3) Engine trouble. (4) Fuel filter clogging. (5) Water is accumulated in fuel pre-filter. (6) Air filter element clogging.	Call your nearest dealer Disassemble/Clean Call your nearest dealer Disassemble/Change Drain water Clean or change of element
Revolution drops before discharge air pressure reaches 100psi(6.9bar).	(1) Pressure regulator insufficient adjustment. (2) Trouble of pressure regulator. (3) Unloader orifice clogging.	Re-adjust (fasten) Change Disassemble/Check
Engine does not reach minimum revolution at unload.	(1) Failure of the engine controller (2) Failure of the accelerator controller.	Call your nearest dealer Call your nearest dealer
Safety valve relieves at unload.	(1) Pressure regulator insufficient adjustment. (2) Unloader valve damaged · Faulty seat (3) Faulty safety valve. (4) Engine speed sensor trouble.	Re-adjust (loosen) Change Change Change
Oil mixes in air. (poor oil separation)	(1) Scavenging orifice strainer clogging. (2) Excessive oil in separator receiver tank. (3) Low discharge pressure. (4) Oil separator deteriorated.	Disassemble/Clean Drain to its proper level Unloader Disassemble/Check Check /Change
Insufficient free air delivery.	(1) Air filter element clogging. (2) Unloader valve cannot fully open. (3) Engine does not reach rated speed.	Clean or change of element Call your nearest dealer Call your nearest dealer

## 5 Failure cause and measures

Symptom	Cause	Countermeasures
It is indicated that engine oil pressure is abnormal, and engine stops.	(1) Engine oil shortage. (2) Engine oil filter clogging. (3) Faulty oil pressure switch. (4) Loosened or disconnected wiring or connector.	Replenish oil Change Change Check/Fasten
It is indicated that coolant temperature is abnormal, and engine stops.	(1) Radiator clogging. (2) Faulty thermostat. (3) Faulty coolant temp. switch. (4) Low coolant level. (5) Belt slippage. (6) Loose wiring, connectors and disconnection. (7) Coolant temp. sensor is disconnected.	Clean Change Change Replenish Re-adjust tension Check/retighten  Repair and replace
It is indicated that discharge air temperature is abnormal, and engine stops.	(1) Oil cooler clogging. (2) Oil filter clogging. (3) Faulty discharged air temp. switch. (4) Loose wiring connectors and disconnection. (5) Slippage of belt. (6) Shortage of compressor oil. (7) Discharge air temp. sensor is disconnected.	Clean Change Disassemble/Check  Check/retighten  Re-adjust tension Replenish oil Repair and replace
Engine monitor alarm lamp glows.	(1) Engine in trouble	※1
Engine trouble lamp and DPF REGENERATION <sup>1</sup> REQUIRED lamp light on.	(1) DPF gets clogged.	Enforced regeneration operation should be performed in the following cases. (Refer to 4.8 clause.)

※1 After having found the cause with a service tool, it is necessary to take measures .  
 Therefore, please contact your nearest distributor.





- Contact your nearest dealer if you find it difficult to repair by yourselves.
- Refer to the engine operation manual for trouble concerning the engine.



## 5 Failure cause and measures

### 5.3 Adjustment of Various data

- The following set values can be altered and adjusted.

No.	Item	Indication	Unit	Primary set value	Range of set values
1	Purge releasing pressure		PSI	86	70~100
2	Waiting time for transfer to purge mode operation		Second	10	5~60
3	Load factor for transfer to purge mode operation		%	15	5~30
4	The high-speed side correction (Full load rotational speed)		min <sup>-1</sup>	100	0~200
5	The low-speed side correction (Unload rotational speed)		min <sup>-1</sup>	100	0~200

#### <Procedures of adjustment>

When SELECT switch is pressed longer (than 5 second), first P. (Purge releasing pressure) is displayed. Each time SELECT switch is pressed, each indication will be selected. Then each time it is pressed one time, T. (Waiting time for transfer to purge mode operation) is switched to b. (Load factor for transfer to purge mode operation) to H. ( Full load rotational speed) to L. (Unload rotational speed), according to the set orders.

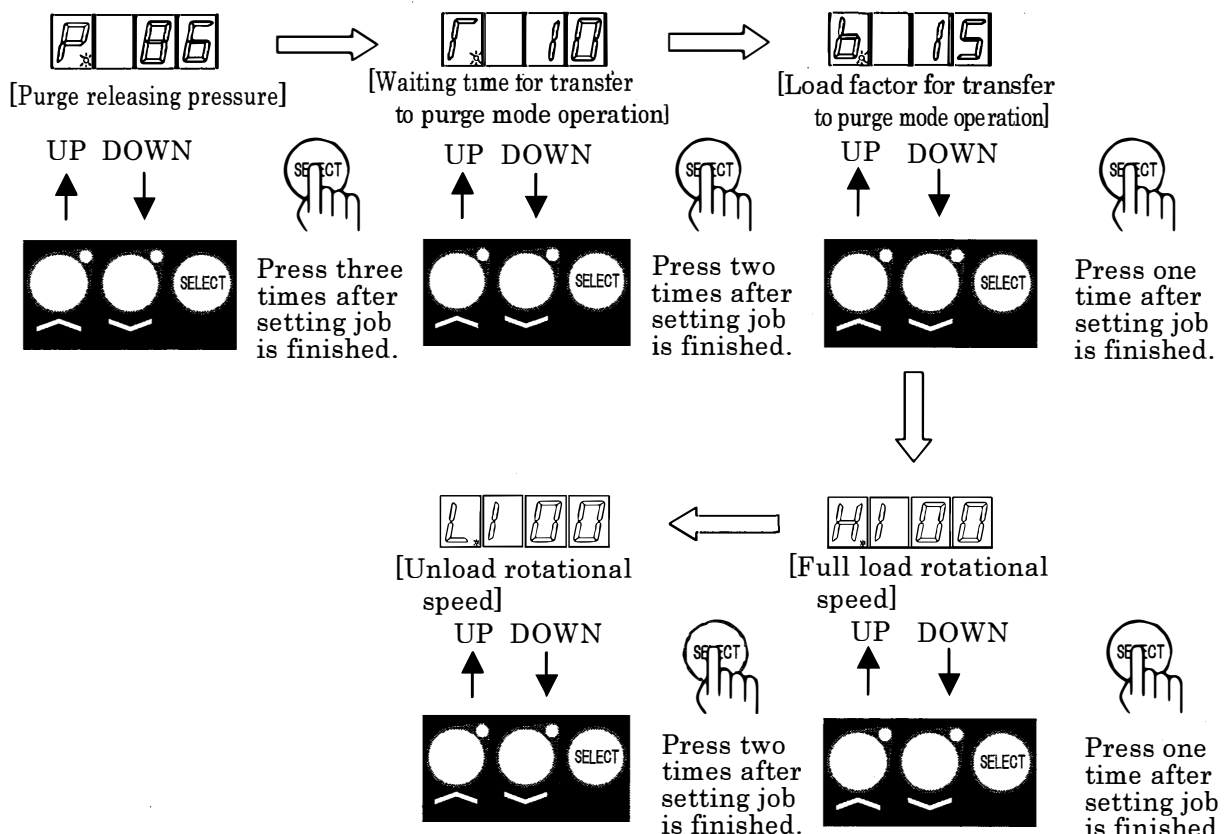



## 6.Periodic Inspection/Maintenance

### 6.1 Important Items at Periodic Inspection and Maintenance or after Maintenance

The following table shows the inspection and maintenance intervals under normal operation conditions. When used or operated under hard environmental conditions, it is impossible to warrant the unit even if the above conditions are performed according to the intervals listed in the above table.

#### **WARNING**

#### **Hang a "Now Checking and under Maintenance" tag**

- Remove the starter key from the starter switch before starting inspection, and hang up a "Now Checking and under Maintenance" tag where it can be easily seen. The checker must keep the key during checking and maintenance.
- Remove the negative (-) side cable from the battery. If the above procedure is neglected, and another person starts operating the machine during check or maintenance, it could cause serious injury.
- Use tools appropriate for the inspection and maintenance. Any makeshift or improper tools could cause unexpectedly injury by their slippage.

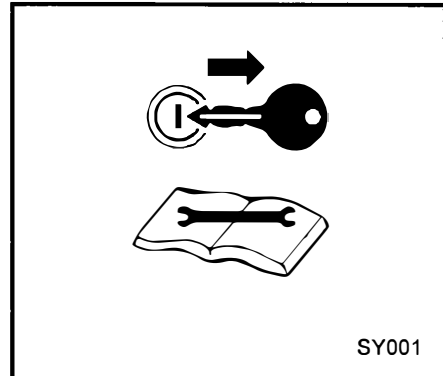

#### **CAUTION**

#### **Prevention of oil separator from catching fire**

- Continuous operation with compressor oil being degraded can cause serious accidents such as a fire accident within the separator receiver tank as well as damages to the bearings. Therefore, in order to prevent such accidents, it is absolutely necessary to replace the whole compressor oil in accordance with the specified schedule of oil replacement. In principle, make sure to strictly follow the scheduled replacement time. Further, whenever the compressor oil is found too much degraded even before the replacement periodical interval comes, it is imperative to replace the oil; complete oil replacement is required. Make sure to use the specified oil.
- Be sure to perform following periodic inspection and maintenance:
  1. Check and change compressor oil
  2. Change oil separator
- Never mix the oil of different brands, or the mixed oil may deteriorate the oil quality.

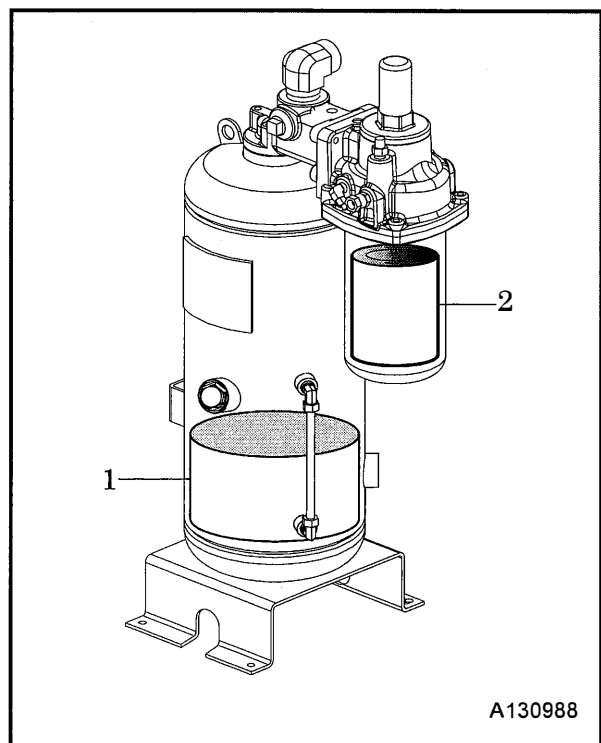

## 6.Periodic Inspection/Maintenance

### IMPORTANT

**Directions: Prohibition of any other jobs or works than directed herein**

- Be sure to use recommended fuel, oil, grease, and antifreeze.
- Do not disassemble or adjust engine, compressor or part(s) for which inspection or maintenance is not referred to in this manual.
- Use genuine parts for replacement.
- Any breakdown, caused by using unapproved parts or by wrong handling, will be out of the scope of "WARRANTY".
- Never perform steam cleaning nor high-pressure cleaning to protect electrical parts.
- Waste from machines contains harmful material. Do not dispose of such harmful fluids to the ground, rivers, lakes or ponds, and sea. It contaminates the environment.
- When draining waste fluid from machines, use leakproof containers to hold such fluids from machine.
- Be sure to follow the designated regulations when disposing of oil, fuel, coolant, filters, battery and other harmful things.

### 6.2 Daily Inspection and Operation Log

- Be sure to carry out daily inspection every morning before operation. See Chapter 4 "Operation" of the manual for the details of inspection.
- Pay attention to and carefully observe the following points during daily operation or inspection and maintenance work. If any trouble or abnormality is found, immediately investigate its cause and make repairs. If the cause is unknown or not traceable, or if the trouble involves a part or component not described in the manual, ask your nearest dealer for information.

- (a) Controls and instruments function properly.
- (b) Quantity and any leak of water, fuel, and oil or any contamination should be checked.
- (c) Appearance, abnormal noise or excessive heat should be checked.
- (d) Loose bolt or nut should be checked.
- (e) Any damage, wear or shortage of machine components and parts should be checked.
- (f) Performance of each part or component should be proper.

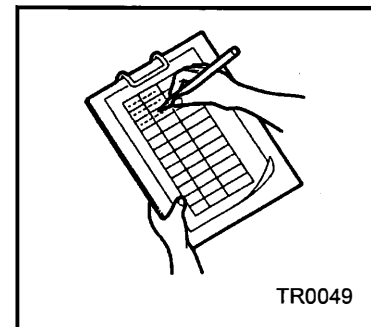

TR0049

- Keep the operation log to record constant inspection of each component, so that trouble of the unit can be easily discovered and preventive measures can be taken.  
It is very useful to record information such as discharge pressure, oil level, as well as running hour, maintenance items and replenishment of lubricant on a daily maintenance log.

## 6.Periodic Inspection/Maintenance

### 6.3 Periodic Inspection List

(Unit:Hour)

Maintenance	Daily	Every 250	Every 300	Every 500	Every 1,000	Every 2,000	Every 3,000	Every 8,000	Page
Check compressor oil level.	○								4-5
Drain separator receiver tank.	○								4-6
Check looseness in pipe connecting part, and wear and tear of pipe.	○								4-7
Check oil, water, fuel and air leak.	○								4-11
Check functions of all instruments and devices.	○								4-11
Change compressor oil.			○ First time	○					6-10
Change compressor oil filter.			○ First time		○				6-11
Clean strainer in the scavenging orifice.				○					6-11
Clean and change air filter element.		○ (Clean)		○ (Change)					6-9
Clean outside of the oil cooler.					○				6-13
Change oil separator.						●			6-15
Change nylon tubes.						☆●			6-15
Change o-ring of unloader.							★●		6-16
Change pressure regulator.							●		6-16
Check rubber hose.							★●		6-16
Check consumable parts of the auto-relief valve.							★●		6-17
Check consumable parts of the vacuum relief valve.							★●		6-17
Performance check of pressure control valve.							●		6-18
Check and change o-ring and piston of pressure control valve.							●		6-18
Inspect solenoid valve.( If it is found good, it is possible to continue to use it.)							●		
Change oil seal and bearing.								●	

Such items marked ○ shall be carried out by customers.

For the following items or clauses marked ●, contact us directly or our distributors because they require expert technical knowledge on them.

The items or parts marked ☆ should be replaced every 2 years even if they are not in disorder within their periodical maintenance interval because their materials will change or become degraded as time passes.

Also for the same reason, the parts marked ★ should be replaced every 3 years.

## 6.Periodic Inspection/Maintenance

◎Refer to engine operation manual for inspection and maintenance of an engine.

(Unit:Hour)

Maintenance	Daily	Every 50	Every 250	Every 500	Every 1,000	Every 2,000	Every 3,000	Page
Drain fuel tank.	○							4-7
Drain check inside fuel pre-filter.	○							4-7
Check fuel.	○							4-6
Check engine oil level.	○							4-4
Check coolant level.	○							4-5
Check looseness in pipe connectors, terminals and tear in wiring.	○							4-7
Check belt tension.	○							4-8
Change engine oil.		○ First time	○					6-6
Change engine oil filter.		○ First time	○					6-6
Check battery electrolyte.			○					6-7
Clean and change air-filter element.			○ (Clean)	○ (Change)				6-9
Change of element inside fuel pre-filter.				○				6-12
Change fuel filter.				○				6-12
Clean outside of radiator.					○			6-13
Change coolant.					○			6-14
Clean inside of radiator.					●			6-13
Cleaning of the EGR cooler						● (Every 1,500 Hour)		※1
Change fuel hose.						☆●		6-15
Clean inside of fuel tank.						●		
Change radiator hoses.							★●	6-17
Clean of DPF							●	※1
Check and cleaning of the EGR valve / reed valve							●	※1
Operational check of the exhaust throttle valve							●	※1
Change and check of the injector							●	※1

※1: Please contact the engine manufacturer.

The items or parts marked ☆ should be replaced every 2 years even if they are not in disorder within their periodical maintenance interval because their materials will change or become degraded as time passes. Also for the same reason, the parts marked ★ should be replaced every 3 years.

(Unit:Hour)

Maintenance	Daily	Every 250	Every 300	Every 500	Every 1,000	Every 2,000	Every 3,000	Page
Supply grease to trailer hub bearing.					○			6-13
Supply grease to leaf spring pin.					○			6-13
Undercarriage	Check and confirm that drawbar is properly fixed with bolts properly, according to specified tightening torque.		○ Every 3 months					6-19
	Check and confirm that the bolts with which undercarriage brackets are fixed are properly tightened.		○ Every 3 months					6-19
	Check and confirm that the nuts with which tires are fixed are properly tightened.		○ Every 3 months					6-20

## 6.Periodic Inspection/Maintenance

### 6.4 Periodic Replacement of Parts

- Part number changes upon modification. For replacement of parts, make sure whether the part number is correct or applicable.

Part Name		Part Number	Quantity
Engine oil filter		41290 01200 (YANMAR 129150-35153)	1
Compressor oil filter		37438 08900	1
Air filter element	For compressor air-end	32143 11800	1
	For engine	32143 11700	1
Fuel filter		43543 02100 (YANMAR 129A00-55800)	1
Element in fuel pre-filter	Element	YANMAR 129A00-55730	1
	O-ring(Element side)	YANMAR 129A00-55740	1
	Drain plug(With O-ring)	YANMAR 129242-55740	1
Oil separator element		34224 03000	1
O-ring		03402 15145	1
Pressure regulator		36400 19000	1
Auto-relief valve & vacuum relief valve	O-ring "1"	21221 02100	2
	O-ring "2"	03402 25021	2
	O-ring "3"	03402 25008	2
Unloader valve	O-ring "1"	03402 10125	2
	O-ring "2"	03402 10070	1
	O-ring "3"	21221 04800	1
	O-ring "4"	21221 04900	1
Pressure control valve	O-ring "1"	03402 15075	1
	O-ring "2"	03402 25032	1
	Spring "3"	22144 07700	1
	Piston "4"	35303 03300	1
Solenoid valve	For starting unloader / For purge	46811 30000	1
Belt		YANMAR 129612-42350	1

## 6.Periodic Inspection/Maintenance

### 6.5 Maintenance Items

#### 6.5.1 Change engine oil

[At 50 hours for the first change and at every 250 hours thereafter]

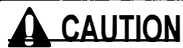

**Caution in filling or discharging engine oil**

- After stopping the engine, wait for 10 to 20 minutes until the engine oil cools off. Then check the level of the engine oil, or refill or drain the oil.
- Engine oil is very hot and highly pressurized during or just after the operation. Hot oil could blow out of the tank and can cause scalding.
- Never supply more engine oil than specified level. excessive supply of engine oil could cause emission of white smoke from exhaust port, too fast revolution of engine and it could cause damage to the internal parts of engine.

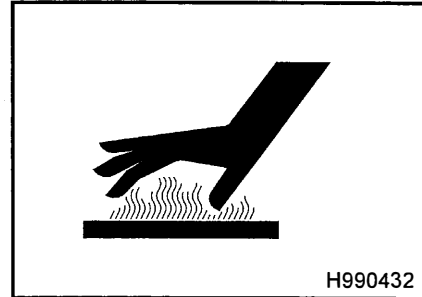

<Procedure>

- ① Remove the drain plug "1" attached outside the plane, open a drain valve "2" inside the plane, and discharge engine oil drain.
- ② When the oil is completely drained, close a drain valve "2" after attaching a drain plug "1", remove the cap of an engine oil filler port "3", refill new engine oil.

**[Quantity of oil : approx. 0.9gal.(3.4L)]**

- ③ After supplying oil, pull out the oil level gauge "4" and wipe it out.
- ④ Then, re-insert the oil level gauge "4" fully and pull it out again. If the dipstick shows the oil level between upper limit and lower limit, it is normal.

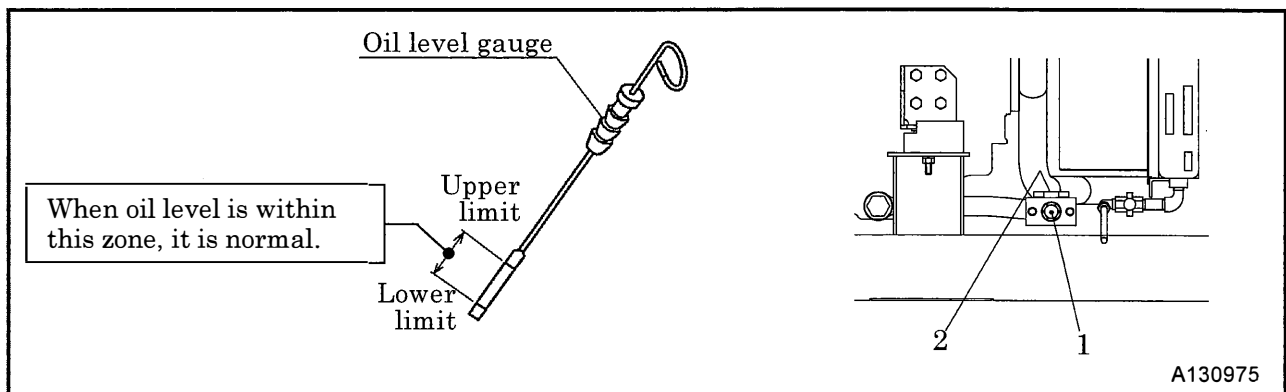
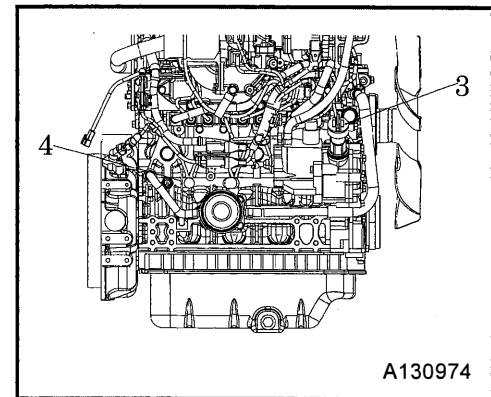

#### 6.5.2 Change engine oil filter

[At 50 hours for the first change and at every 250 hours thereafter]

<Procedure>

- ① Remove the cartridge "1", using a filter wrench.
- ② Screw in the new cartridge "1" with the packing "2" coated slightly with oil. **(For part number, see 6.4)**
- ③ After the packing touches the sealing face, further tighten it by turning it 3/4 times with the filter wrench.
- ④ After installing the oil filter, check it for any leak during operation.

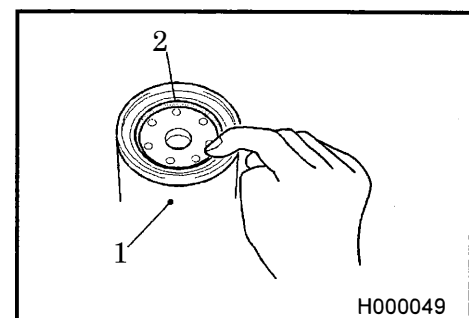

## 6.Periodic Inspection/Maintenance

---

### 6.5.3 Check battery electrolyte [Every 250 hours]

If there seems to be a problem in starting an engine due to a flat battery, carry out the checks by following the procedures below:

#### 1. Ordinary type battery:

Check battery electrolyte level and if the level is not within the specified level, add distilled water.

Measure the specific gravity of the battery electrolyte, and if it shows below 1.24, recharge the battery immediately. **(See 6.5.4)**

#### 2. Enclosed type battery:

Check the indicator on top surface of the battery.

If the indicator shows that charge is needed, recharge the battery immediately.



## 6.Periodic Inspection/Maintenance

### 6.5.4 Maintenance of Battery

#### WARNING

- Keep flames away from battery.
  - Battery may generate hydrogen gas and may explode.
  - Therefore, recharging should be done at a well-ventilated place.
  - Do not spark near the battery nor light a match, nor bring lit cigarette and match close to the battery.
- Do not check the battery by short-circuiting the positive and negative terminals with a metallic piece.
- Never operate the machine nor charge the batteries with the battery liquid level being kept lower than the "LOWER" level. Continuing operation at this lower level will cause deterioration of such parts as pole plates etc., and also it may cause explosion as well as reduction of battery life.
- Add distilled water so that the liquid level may reach the middle level between the "UPPER" and "LOWER" level without any delay.
- Do not charge the frozen battery. Otherwise it may explode. If the battery is frozen, warm it up until the battery temperature becomes 16°C to 30°C.
- Battery electrolyte is dilute sulfuric acid. In case of mishandling, it could cause skin burning.
- Wear protective gloves and safety glasses when handling a battery.
  - When such battery electrolyte contacts your clothes or skin, wash it away with large amount of water immediately.
  - If the battery electrolyte gets into your eyes, wash it away immediately with plenty of water and see a doctor at once, because it is feared that eyesight might be lost.
- Dispose of battery, observing local regulations.

#### Handling battery



D004

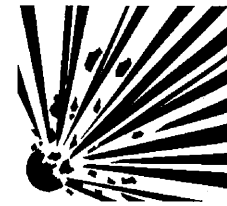

W010



TR0093

#### [Charge Battery]

- Disconnect the cable between battery and the unit, and charge the battery with a 12 V battery charger. Do not charge two batteries at the same time.
- Be sure not to connect (+) and (-) terminals backwards.
- Be sure to read the operation manual of the battery charger to know if it is applicable, before using it.

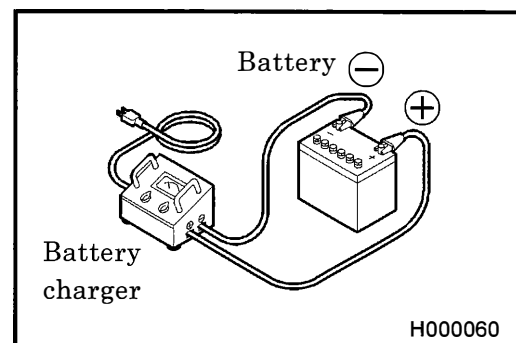

H000060



## 6.Periodic Inspection/Maintenance

### [How to Use Booster Cable]

#### **CAUTION**

***Do not reverse the cable connection***

- When a booster cable has to be used or when cables are connected again after an battery is replaced, be careful not to connect (+) and (-) terminals backwards. Such wrong-connection will cause spark and damage to each component.

<Procedure for using a booster cable>

- ① Stop the engine.
- ② Connect one end of the (+) cable to the (+) terminal of the machine battery.
- ③ Connect the other end of the (+) cable to the (+) terminal of the external battery.
- ④ Connect one end of the (-) cable to the (-) terminal of the external battery.
- ⑤ Connect the other end of the (-) cable to the engine block of the machine.
- ⑥ Start up the engine.
- ⑦ Disconnect the booster cable by following the procedure back in the reverse order.

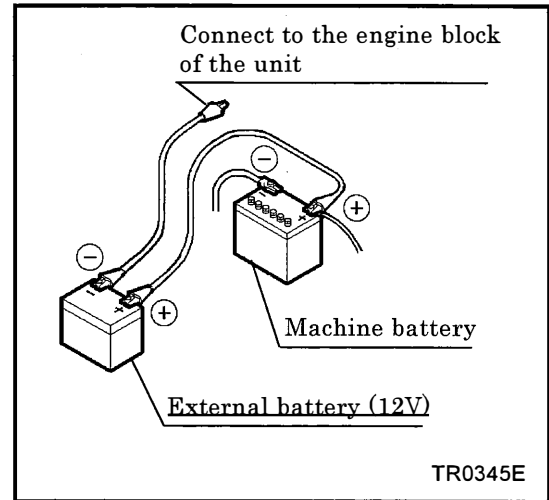

### 6.5.5 Check and clean a clogging air filter element [Every 250 hours]

#### **IMPORTANT**

***Cleaning of air filter element should be perfectly performed***

- Clogged or cracked or pitted element could allow entrance of dust into engine and compressor to cause earlier wear of moving parts. Periodical inspection and cleaning of element should be performed to maintain life of compressor and engine long.

<Procedure>

- ① After removing the cap "1" by loosening its latch "2", clean its interior properly.
  - ② Take out element "3", and clean it.
  - ③ When installing the cap after it is cleaned, hold the case "5" securely by hand so that O-ring "4" may not protrude from it, and retighten it after checking and confirming that the latch hook for fixing the cap is engaged to the case.
- Not limited to the above, be sure to replace any element with a new one in the case in which it is heavily stained.

(For part numbers, refer to 6.4 )

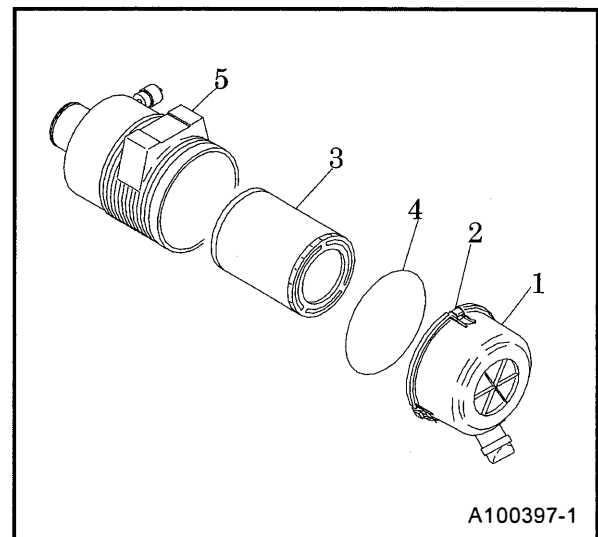

## 6.Periodic Inspection/Maintenance

### 6.5.6 Change compressor oil

[At 300 hours for the first change and at every 500 hours thereafter]



#### Refilling of compressor oil

- When you refill the separator receiver tank with compressor oil, stop the engine, and make sure that the pressure gauge indicates 0psi(0bar) and there is no residual pressure in it, and then gradually loosen the oil filler cap for refilling oil.
- Note residual pressure in the receiver tank could force both extremely hot compressed air and oil to jet out and you may be scalded or seriously injured.
- Even continuous oil replenishment cannot improve its deteriorated condition. Be sure to change the oil completely at every scheduled interval.
- Do not mix it with other brand oil, or it will cause poor performance and shorten the life of the compressor oil. (But fresh compressor oil could accept a mixture of small amount of different brands.)
- Running the unit with old and deteriorated compressor oil will cause damage to bearings, or serious accident like ignition in a separator receiver tank. Be sure to change the oil completely at every scheduled interval.
- Follow the designated regulations to dispose of compressor oil.

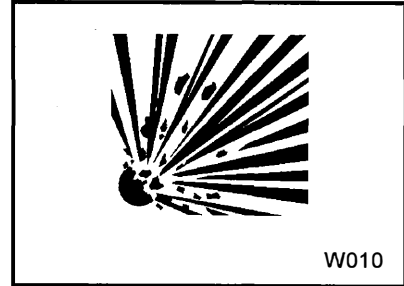

#### <Procedure>

- ① After residual pressure is completely relieved from separator receiver tank, remove oil filler cap "1" and open drain valve "2" for draining oil. And then open drain valve "4" of oil cooler for draining also the oil accumulated in bottom of oil cooler.
  - ② After compressor oil is completely drained out, close drain valve "2" and "4" for sure.
  - ③ After refilling fresh compressor oil up to the upper limit of level gauge, close oil filler cap "1". Check o-ring "3" of oil filler cap "1" whether it is hardened and/or damaged. If it is found damaged or hardened, replace it with a new one.
  - ④ Start the engine for a short while, then replenish the oil to fill shortage. Repeat this procedure for 1 to 2 times to check if the oil level has reached its appropriate point. Be careful not to overfill the oil.
- If oil is cold when it is changed, it takes a longer time to drain oil completely. But make sure to drain oil completely.

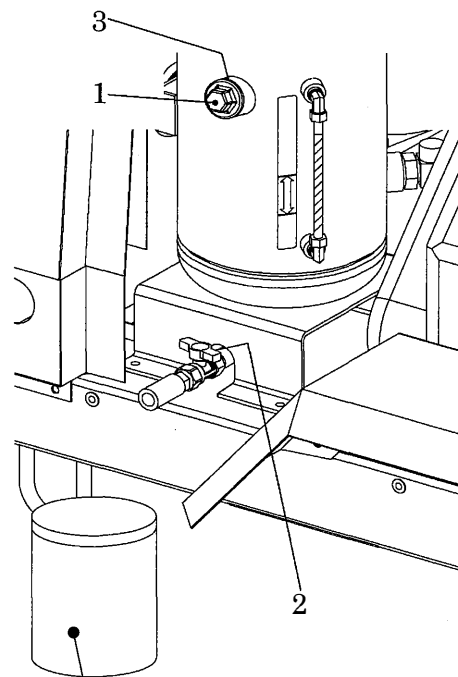

Receiver of drained condensate

A130976

Oil quantity to be changed	Approx.3.96gal.(15L)
----------------------------	----------------------

## 6.Periodic Inspection/Maintenance

### 6.5.7 Change compressor oil filter

[At 300 hours for the first change and every 1,000 hours thereafter]

**IMPORTANT**

*Use our genuine oil filter*

- Poor quality oil filters do not trap dust sufficiently and will cause damage to the bearings in a short period.

<Procedure>

- ① Remove the cartridge "1", using a filter wrench.
- ② Screw in the new cartridge "1" with the packing "2" coated slightly with oil. **(For part number, see 6.4)**
- ③ After the packing "2" touches the sealing face, further tighten it by turning it 3/4 time with the filter wrench.
- ④ After installing the oil filter, check it for any leak during operation.

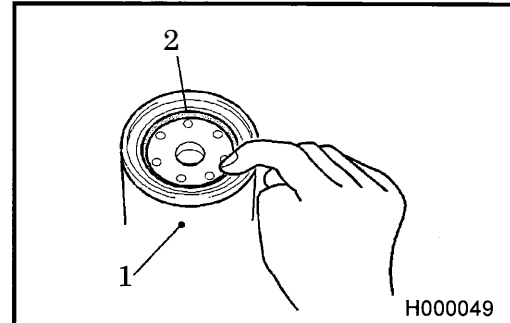

### 6.5.8 Clean strainer in the scavenging orifice [Every 500 hours]

<Procedure>

- ① Remove the pipe "1", using a spanner.
- ② First remove the bushing "2".
- ③ Then remove the strainer "3".
- ④ Wash the removed strainer in diesel oil and blow out "dust" by air blowing.
- ⑤ After finishing the cleaning, install the strainer again in the reverse procedure.

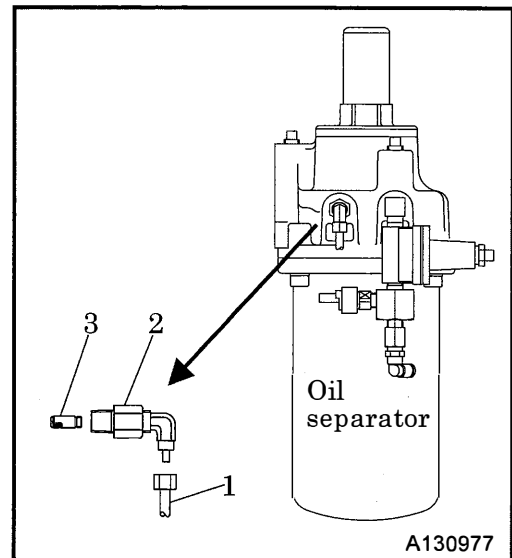

### 6.5.9 Change air filter element [Every 500 hours]

**IMPORTANT**

*Use our genuine part*

- Air filter is an important part which is crucial to machine's performance and life.  
Be sure to use genuine parts.

<Procedure>

- ① After removing the cap "1" by loosening its latch "2", clean its interior properly.
- ② Remove the element "3" and then replace it with a new one.  
**(For part numbers, refer to 6.4)**
- ③ When installing the cap, surely push the O-ring "4" to the case "5" with a hand and then tighten it after checking and confirming that the hook of the cap fixing latch is caught in the case.

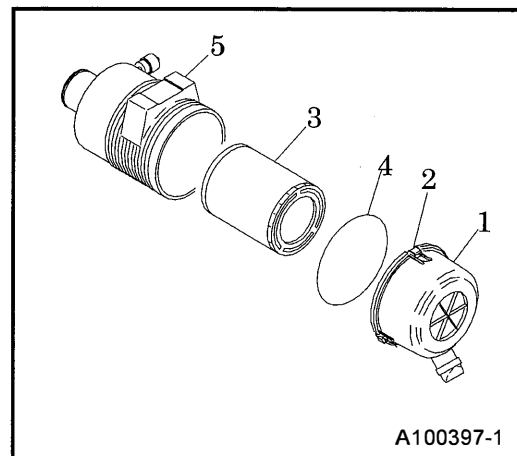

## 6.Periodic Inspection/Maintenance

### 6.5.10 Change of element in Fuel pre-filter [Every 500 hours]

<Procedure>

- ① Turn fuel selector valve "1" to "OFF" position.
- ② Loosen the drain valve "2" and drain out condensed water inside.
- ③ Turn the cup "3" to the left and remove it.  
Be careful to remove the cup "3" because it is filled with fuel. Wipe out split fuel completely.
- ④ Remove float "4" inside cup "3" .
- ⑤ Washing element "5" and the cup inside with new fuel.
- ⑥ Replace element and o-ring if they are found broken or damaged. **(For part number, see 6.4)**
- If air is found still in fuel pipe, place starter switch to "RUN" position and loosen air bleeding bolt "6" to bleed air. After finishing air bleeding, tighten the air bleeding bolt "6" .
- Drain the condensate in container, and then dispose of condensate according to the designated regulations.

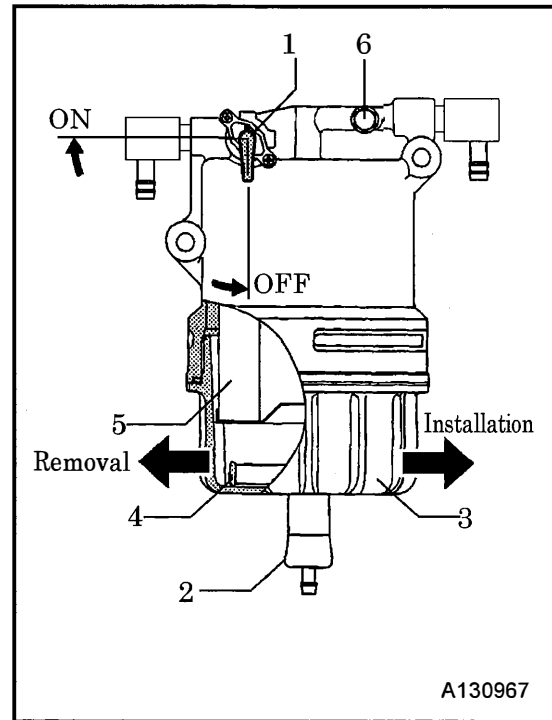

### 6.5.11 Change fuel filter [Every 500 hours]

<Procedure>

- ① Use a filter wrench to remove the cartridge "1"
- ② Spread thin film of oil on a packing "2" of a new cartridge "1" and screw it in.  
**(For part number, see 6.4)**
- ③ After the packing "2" touches the sealing face, tighten it by rotating it one of a turn or one turn using a filter wrench.
- ④ After installing oil filter, be sure to check for oil leak during the operation.

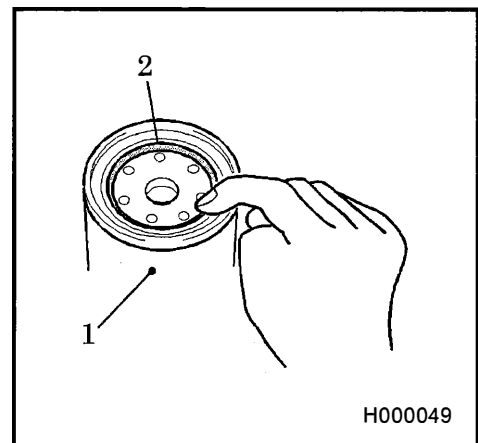

## 6.Periodic Inspection/Maintenance

### 6.5.12 Clean outside of the radiator ·oil cooler [Every 1,000 hours]

- When the fin tubes diaphragm “1” , of a radiator, and an oil cooler are clogged with dust or other foreign materials, the heat exchange efficiency drops and this will raise coolant temperature and discharge air temperature. These tubes and fins should be cleaned depending on the state of clogged tubes diaphragm “1” , even before maintenance schedule.
- Do not use a high pressure washer to protect fin tubes from being damaged.

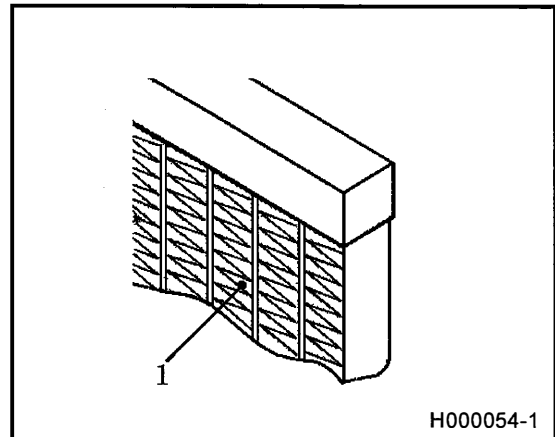

### 6.5.13 Clean inside of radiator [Every 1,000 hours]

- When the inside of a radiator and water conduits of an engine are dirty with scale and rust, its cooling efficiency will be deteriorated. Clean the interiors of such components periodically.
- When cleaning it, contact directly us or distributor because it requires expert technical knowledge.

### 6.5.14 Supply grease to trailer hub bearing [Every 1,000 hours]

- Call your nearest dealer for replenishing grease to the trailer hub bearing.

**Grease: Chassis grease**

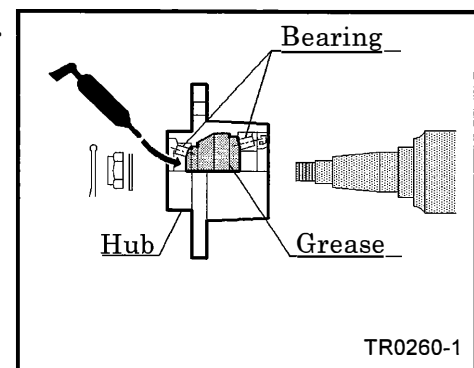

### 6.5.15 Supply grease to leaf spring pin [Every 1,000 hours]

- Supply grease through grease nipples positioned at the bottom.

**Grease: Chassis grease**

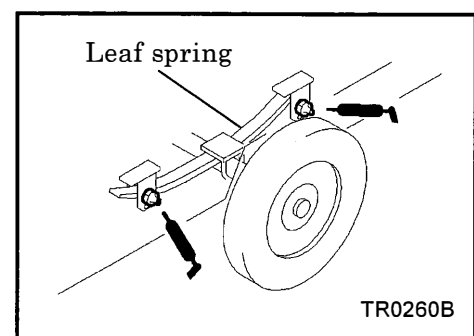

## 6.Periodic Inspection/Maintenance

### 6.5.16 Change coolant [1,000 hours or every 1 years]



**Caution in filling or discharging engine oil**

- Be sure to stop the machine and allow time to cool. Then loosen the radiator cap one notch. After the coolant water is sufficiently cooled and the inner pressure is released, take the cap off.  
If this procedure is neglected, the inner pressure can blow off the cap. Steam jetting out of the radiator could result in causing scalding. Follow this procedure under all circumstances.

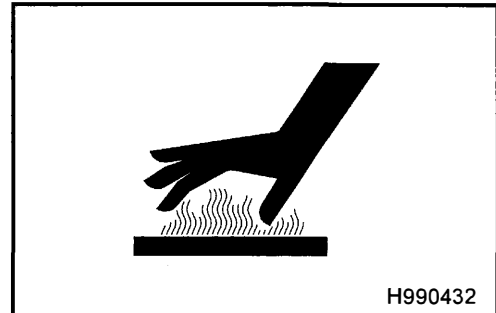

- LLC (Antifreeze) is a toxic material.
  - When a person has drunk LLC (Antifreeze) by accident, make him vomit and see a doctor immediately.
  - When a person gets LLC (Antifreeze) in his eyes, wash the eyes with clean running water and make him see a doctor immediately.
  - When LLC (Antifreeze) is stored, put it in a container with an indication saying "LLC (Antifreeze) inside" and seal it up, then keep it in a place away from children.
  - Beware of flames.

#### <Procedure>

- ① To drain coolant, remove the radiator cap "1" Remove operation side radiator drain plug "2" and open drain valve "3" for drainage.
- ② Furthermore, be sure to drain engine by loosening the drain plug "3" without fail.
- ③ After completing the drainage, close the drain valve and drain plug , then supply coolant through the filler port.  
**[Quantity of water : approx. 1.93gal.(7.3L)]**
- ④ After coolant is filled up, run the machine in the unloaded condition for approximately 2 to 3 minutes and stop it. Then check coolant level again. When the level is low, replenish it.

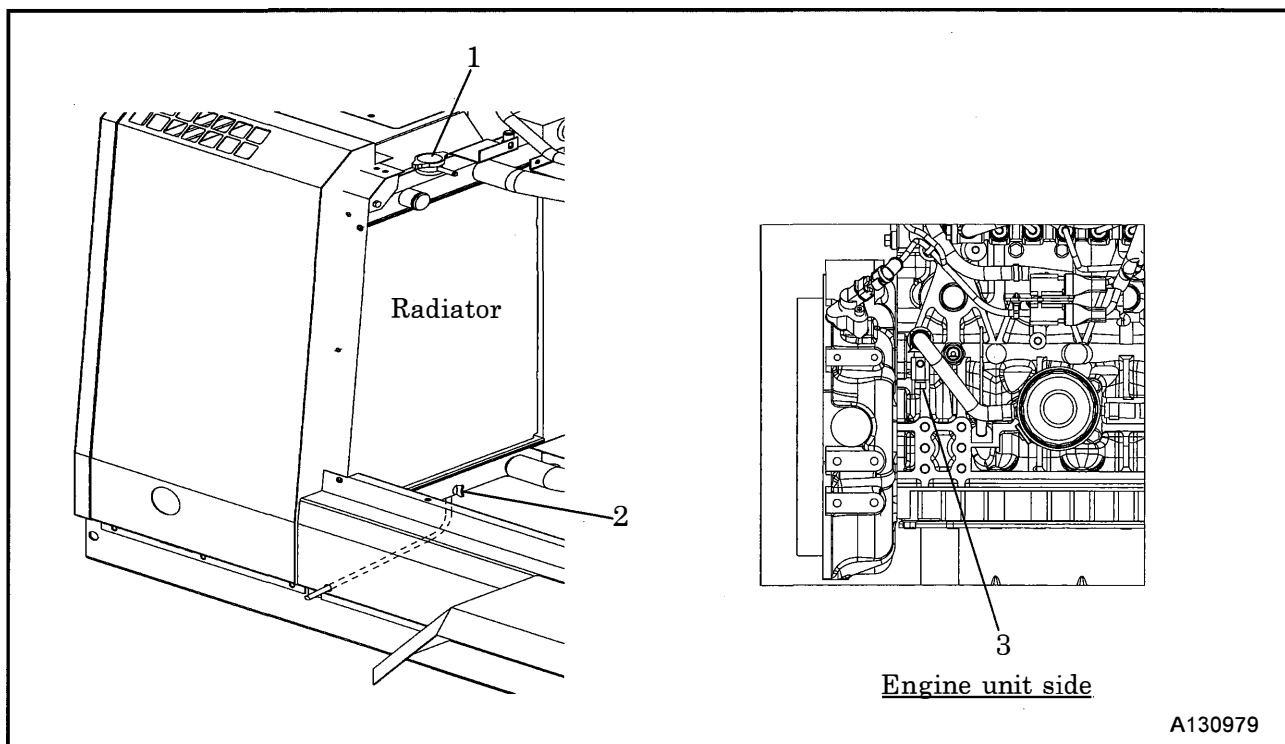

A130979

## 6.Periodic Inspection/Maintenance

### 6.5.17 Change oil separator [Every 2,000 hours]

#### IMPORTANT

- When changing the oil separator, both cover and element must be replaced with new ones.
- Even before the periodic interval time of replacement, replace the oil separator whenever the oil consumption increases and also oil is found mixed in the discharge air.
- When consumption of the oil is still unusual even after cleaning strainer in the scavenging orifice (See 6.5.8), change the oil separator with a new one. **(For part number, see 6.4)**
- When replacing oil separator, contact directly us or distributor because it requires expert technical knowledge.

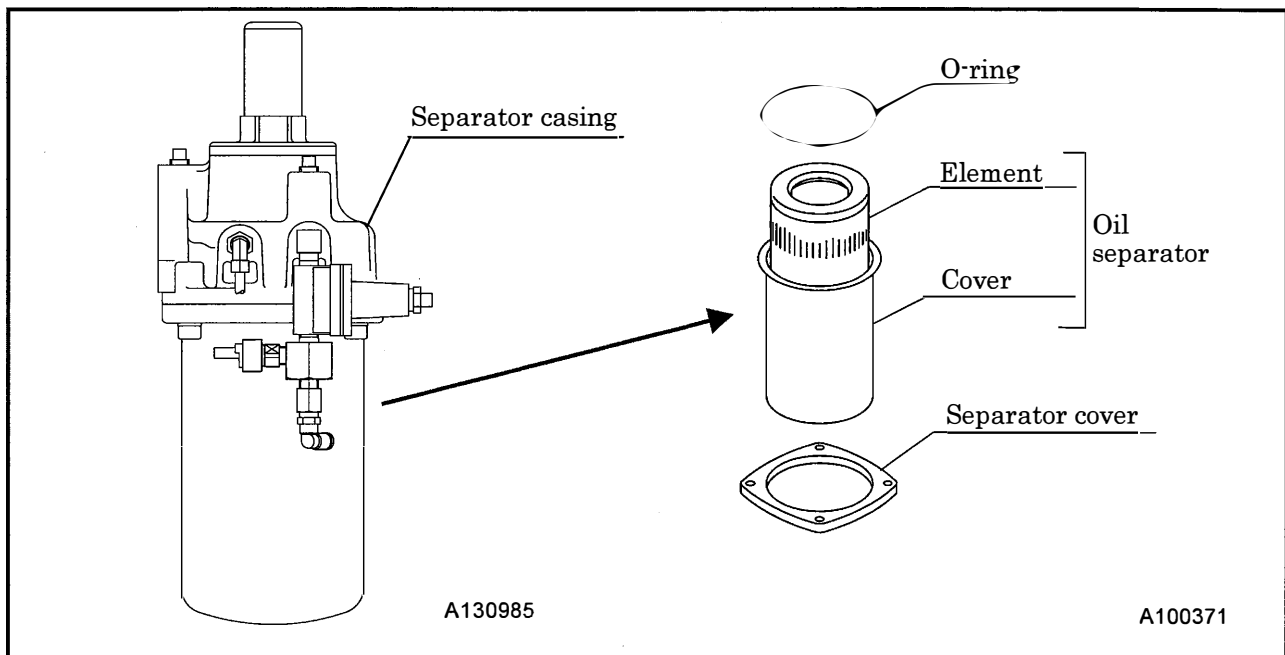

### 6.5.18 Change nylon tubes [2,000 hours or every 2years]

- Replace nylon tubes used for the oil and air pipings.
- When replacing it, contact directly us or distributor because it requires expert technical knowledge.

### 6.5.19 Change fuel hose [2,000 hours or every 2years]

- In case various rubber hoses for fuel system and engine lubrication system are hardened or deteriorated, replace them even before the specified replacement time.
- When replacing hoses, contact directly us or distributor because it requires expert technical knowledge.



## 6.Periodic Inspection/Maintenance

### 6.5.20 Change pressure regulator [Every 3,000 hours]

- Remove pressure regulator and rebuild or replace with a new unit. **(For part number, see 6.4)**

### 6.5.21 Change o-ring of unloader [3,000 hours or every 3 years]

#### IMPORTANT

- When reassembling, apply sufficient grease to O-ring Slot/O-ring and sliding surface.  
Use CALTEX MULTIFAK EP1 grease or equivalent. Grease of poor quality will deteriorate the material.

<Caution during O-ring replacement>

Supply grease to O-ring "1" , "2" , "3" , "4" after replacement.

**(For part number, see 6.4)**

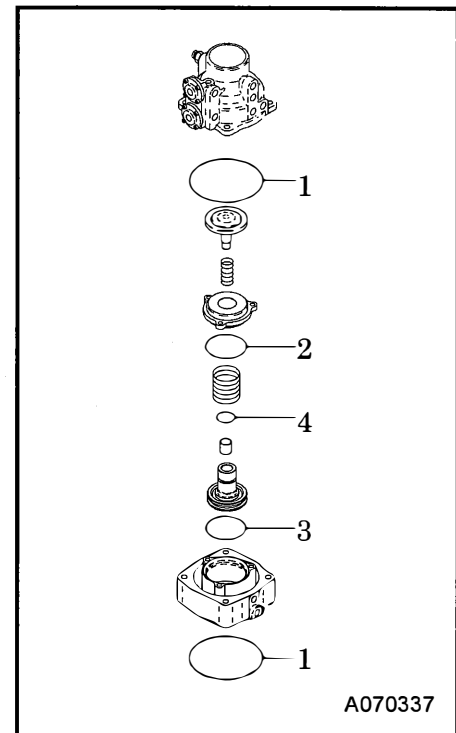

### 6.5.22 Check rubber hose [3,000 hours or every 3 years]

- Check hoses used for oil piping for any crack or tear, and replace when an abnormality is found.
- When replacing hoses, contact directly us or distributor because it requires expert technical knowledge.



## 6.Periodic Inspection/Maintenance

### 6.5.23 Change radiator hoses [3,000 hours or every 3 years ]

- When any crack or wear is found on the hoses, change it even before the scheduled time.
- When replacing it, contact directly us or distributor because it requires expert technical knowledge.

### 6.5.24 Check consumable parts of the auto-relief valve and vacuum relief valve [3,000 hours or every 3 years]

#### IMPORTANT

- When reassembling, apply sufficient grease to O-ring Slot/O-ring and sliding surface.  
Use CALTEX MULTIFAK EP1 grease or equivalent. Grease of poor quality will deteriorate the material.

- After disassembling and cleaning the auto-relief valve, check the O rings “1”, “2” and “3”. When the rubber of these rings is found hardened, replace any one of them.

(For part number, see 6.4)

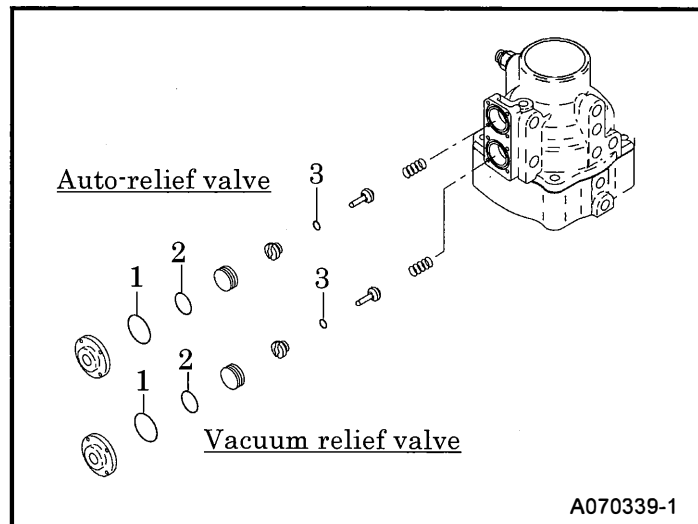

A070339-1

## 6.Periodic Inspection/Maintenance

### 6.5.25 Performance check of pressure control valve [3,000 hours or every 3 years]

#### IMPORTANT

- When reassembling, apply sufficient grease to O-ring Slot/O-ring and sliding surface. Use CALTEX MULTIFAK EP1 grease or equivalent. Grease of poor quality will deteriorate the material.

#### <Procedure>

- ① When closing stop valve and fully opening service valve while the machine is running, make sure that the discharge pressure gauge shows the figure between 49 to 68psi(3.4 to 4.7bar).
- ② When the pressure is lower than 49psi(3.4bar), replace spring "3" with a new one.

**(For part number, see 6.4)**

- ③ When the indicator shows excessively higher pressure, you will find that the piston does not move smoothly due to foreign material and rust stuck inside valve. In such a case, disassemble the component for checking and cleaning.

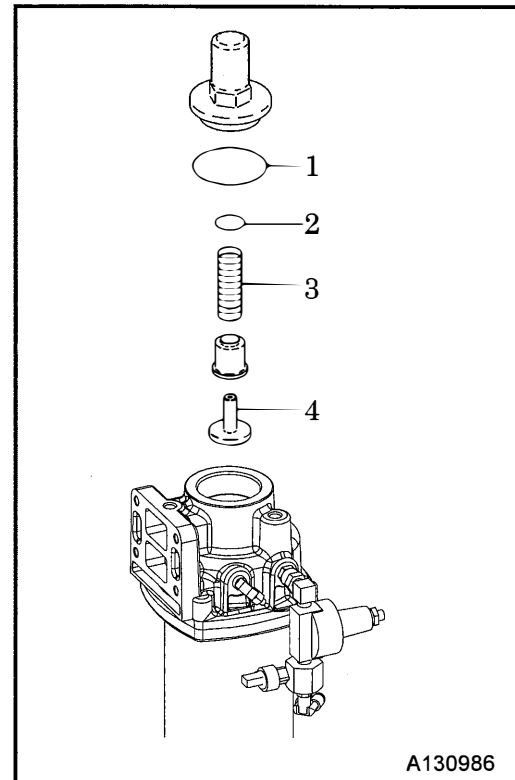

### 6.5.26 Check o-ring and piston of pressure control valve

- After disassembling and cleaning pressure control valve, check O ring "1" , "2" and piston "4" . When the rubber of these parts is found hardened, or damaged, replace them.

**(For part number, see 6.4)**

- When replacing it, contact directly us or distributor because it requires expert technical knowledge.
- After replacement, run the machine to check its function (**See 6.5.25**), air-leak or any disorder.

## 6.Periodic Inspection/Maintenance

### 6.5.27 Check and confirm that drawbar is properly fixed with bolts properly, according to specified tightening torque.

**[ Every 3 months ]**

- Check and confirm once every three months that the bolts with which drawbar is fixed are not loosened. (11 points)
- If it is found that specified tightening torque of clamped bolts drops to a lesser value, retighten them to correct specified value.

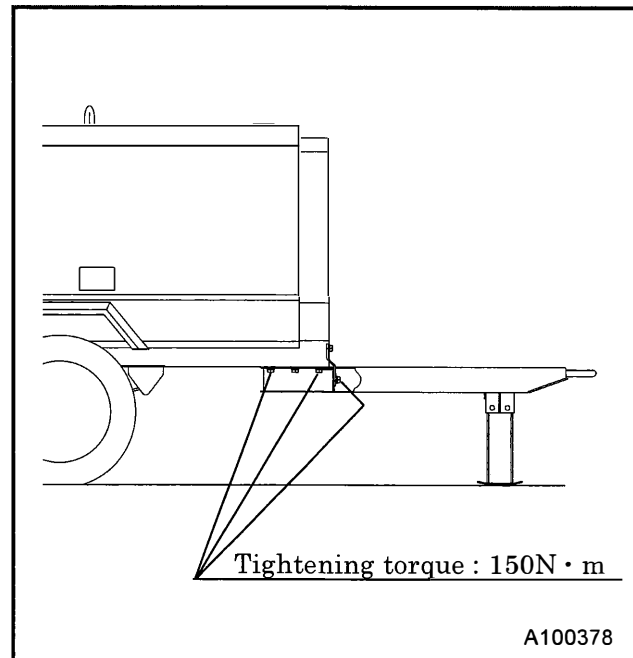

### 6.5.28 Check and confirm that the bolts with which undercarriage brackets are fixed are properly tightened.

**[ Every 3 months ]**

- Check and confirm once every three months that there is no looseness in tightening bolts. (8 points)
- If it is found that specified tightening torque of clamped bolts drops to a lesser value, retighten them to correct specified value.

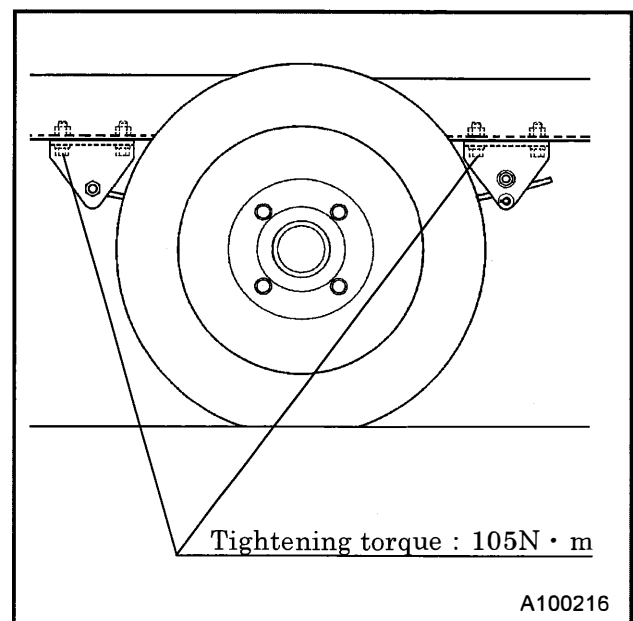

## 6.Periodic Inspection/Maintenance

### 6.5.29 Check and confirm that the nuts with which tires are fixed are properly tightened.

[ Every 3 months ]

- Check and confirm once every three months that hub nuts with which tires are fixed are not loosened. (8 points)
- If it is found that specified tightening torque of clamped bolts drops to a lesser value, retighten them to correct specified value. (Standard pressure for a tire is at 450kPa.)

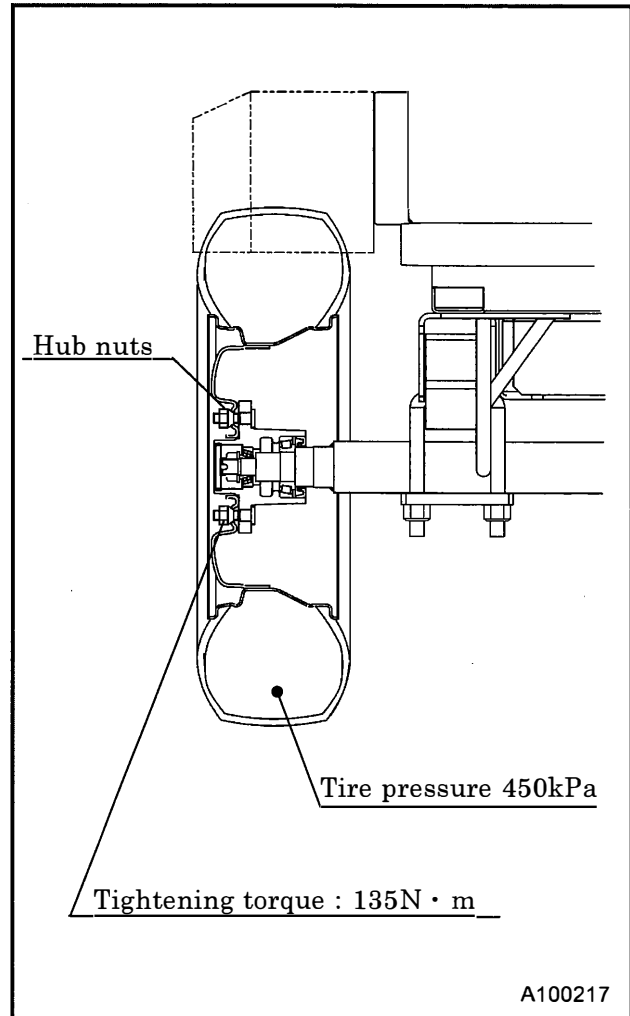

## 7. Long-term Storage and Disposal of Product

---

### 7.1 Preparation for Long-term Storage

When the machine is left unused or not operated longer than half a year (6 months), store it at the dry place where no dust exists after the following treatments have been done to it.

- Put the machine in a temporary cabin if it is stored outside. Avoid leaving the machine outside with a sheet cover directly on the paint for a long time, or this will cause rust to the machine.
- Perform the following treatments at least once every three months.

#### <Procedure>

- ① Drain existing lubricant from the engine oil pan. Pour new lubricant in the engine to clean its inside. After running it for a while, drain it again.
- ② Completely charge the battery and disconnect grounding wires. Remove the battery from the machine, if possible, and store it in a dry place. (Charge the battery at least once every month.)
- ③ Drain coolant and fuel from the machine.
- ④ Seal the engine, air-intake port and other openings like the muffler with a vinyl sheet, packing tape, etc., to prevent moisture and dust from getting in the machine.
- ⑤ Be sure to repair any trouble and maintain the machine so that it will be ready for the next operation.

### 7.2 Disposal of products

- In case of disposal of this unit, at first drain the cooling water and oils.  
For any points unclear to you, please contact us or our local agent for further information.

## 8. Specifications

### 8.1 Specifications

Model		PDS185S-6E1	
Compressor	Type		Single-stage oil cooled, screw type compressor
	Free air delivery	cfm (m <sup>3</sup> /min)	185 (5.2)
	Working pressure	psi (bar)	100 (6.9)
	Lubricating system		Forced Lubrication by compressed pressure
	Driving system		Direct driving with gear coupling
	Receiver tank capacity	cu in. (m <sup>3</sup> )	1,221 (0.021)
	Lubricating oil capacity	gal. (L)	3.96 (15)
Engine	Model		YANMAR 4TNV88C-DHKS
	Type		Water-cooled 4-cycle direct injection
	Number of cylinders, bore stroke	in. (mm)	4-3.46in. × 3.54in. (4- 88mm × 90 mm)
	Total displacement	cu in. (L)	133.6 (2.189)
	Rated output(GROSS)	kW/min <sup>-1</sup>	35.5 / 3,000
	Rated output(NET)		34.0 / 3,000
	Lubricating oil capacity	gal.(L)	0.9 (3.4) (The amount of initial filling)
			Approx. 0.9 (3.4) (The amount of exchange)
	Coolant capacity (including radiator)	gal. (L)	1.93 (7.3)
	Battery		95D31R (12V)
Fuel tank capacity	gal. (L)	24 (90)	
General Specifications	Overall length	in. (mm)	128.7 (3,270)
	Overall length (Bonnet only)	in. (mm)	75.2 (1,910)
	Overall width	in. (mm)	66.3 (1,685)
	Overall height	in. (mm)	61 (1,550)
	Net dry mass	lb (kg)	2,050 (930)
	Operating mass	lb (kg)	2,271 (1,030)

**8.2 Outline drawing**

**8. Specifications**

Unit : in.

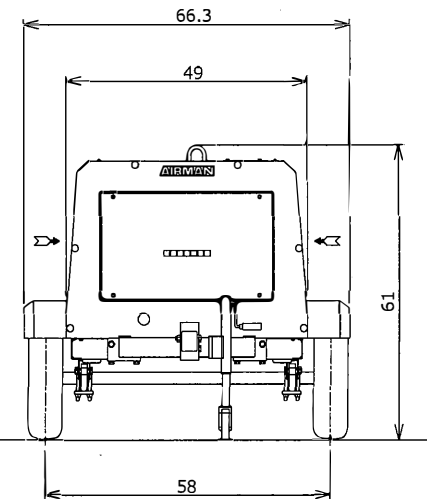
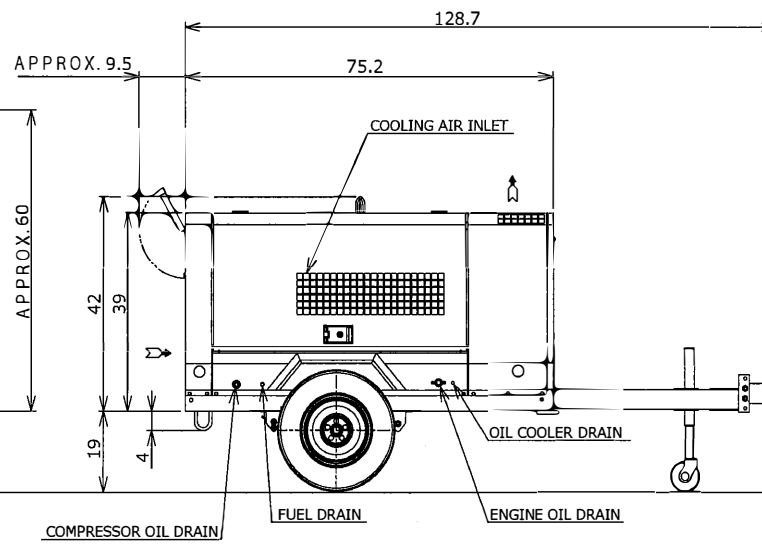
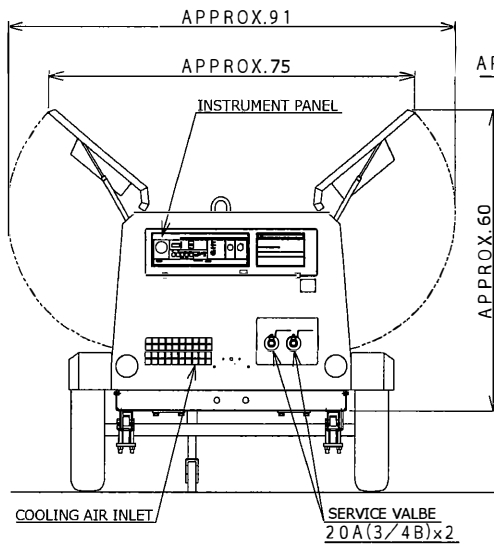
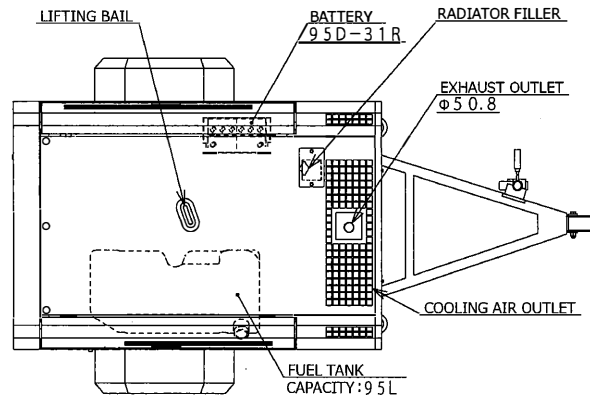
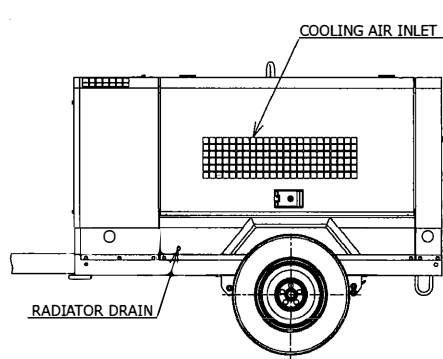

8-2

A131026

Unit : mm

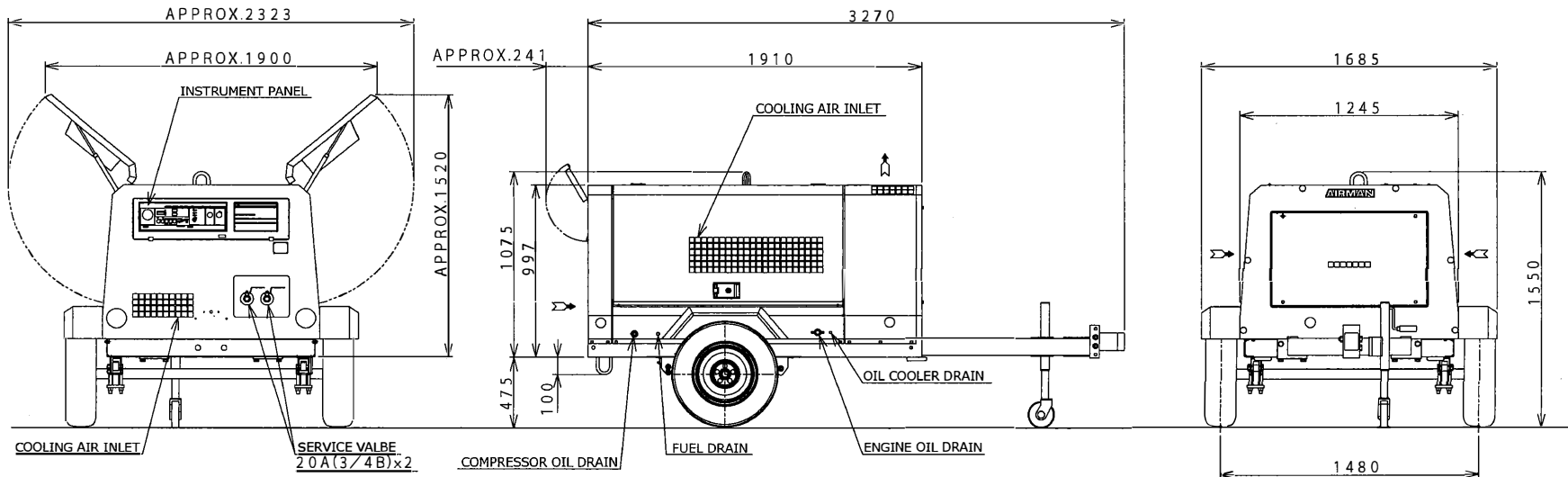
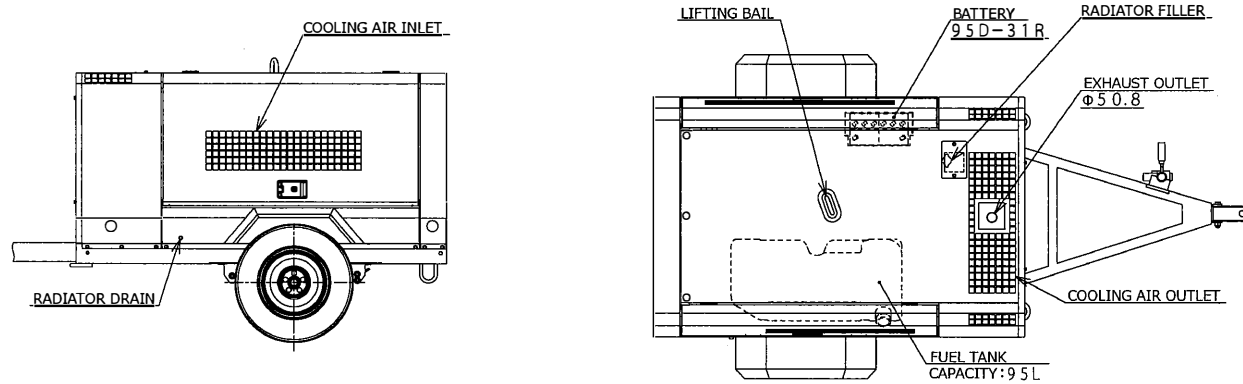

A131025



# MEMO

---

---

---

---

---

---

---

---

---

---

---

---

---

---

---

---

---

---

---

---

---

---

---

---

---

---

---

---

# 9. Wiring Diagram

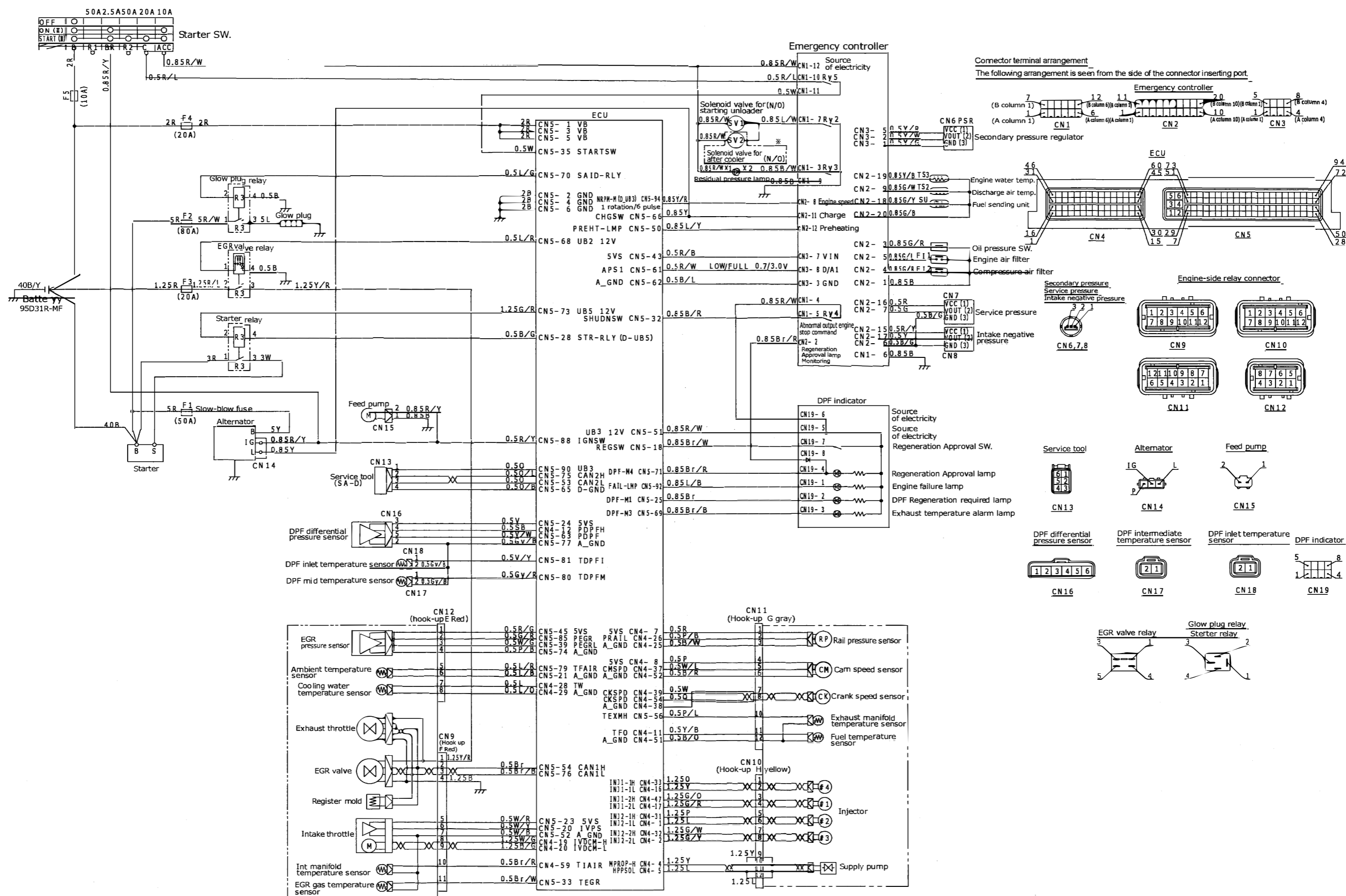

# 10.Piping Diagram

## 10.1 Air piping · Compressor oil piping

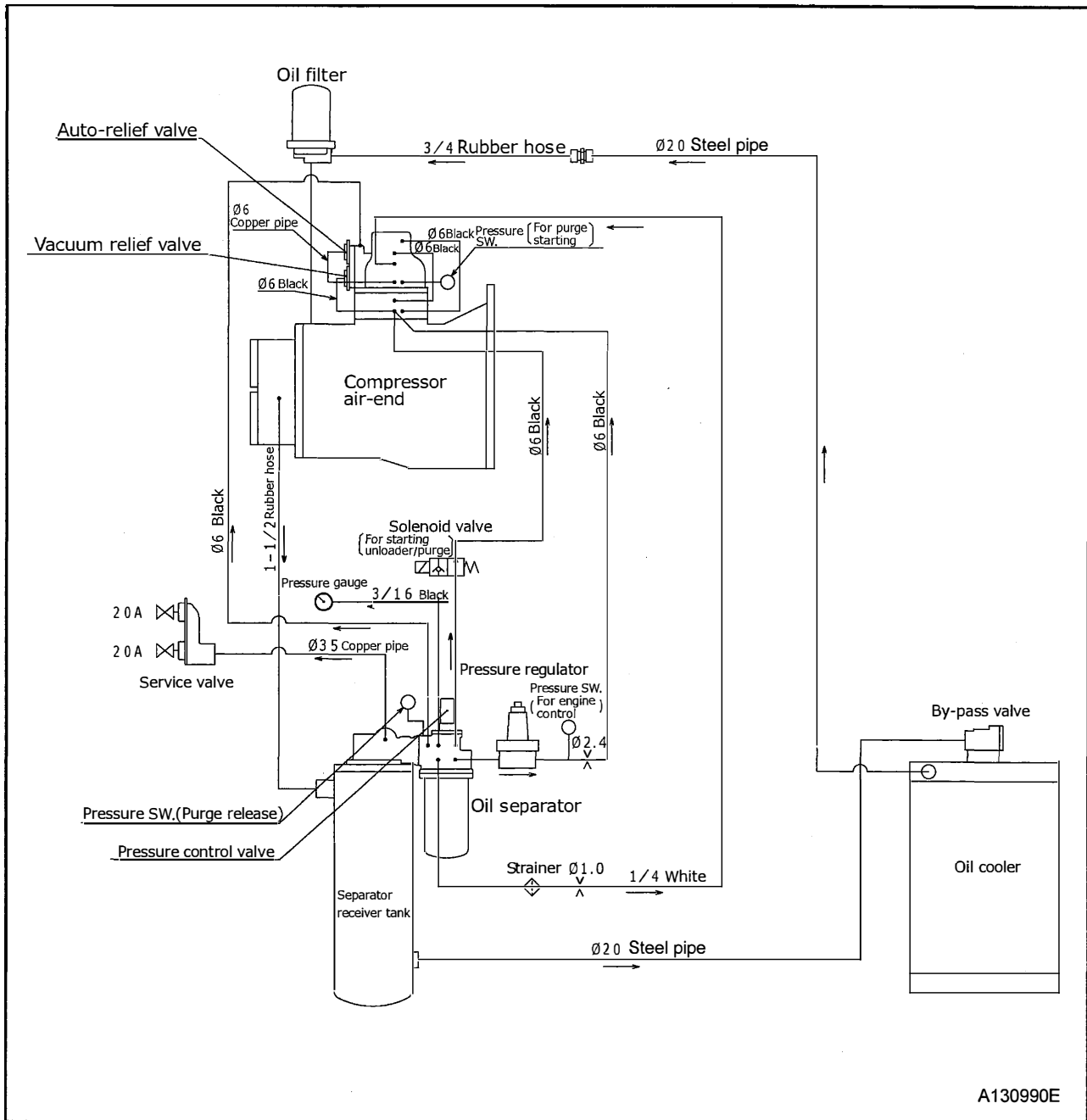

# 10.Piping Diagram

## 10.2 Fuel piping

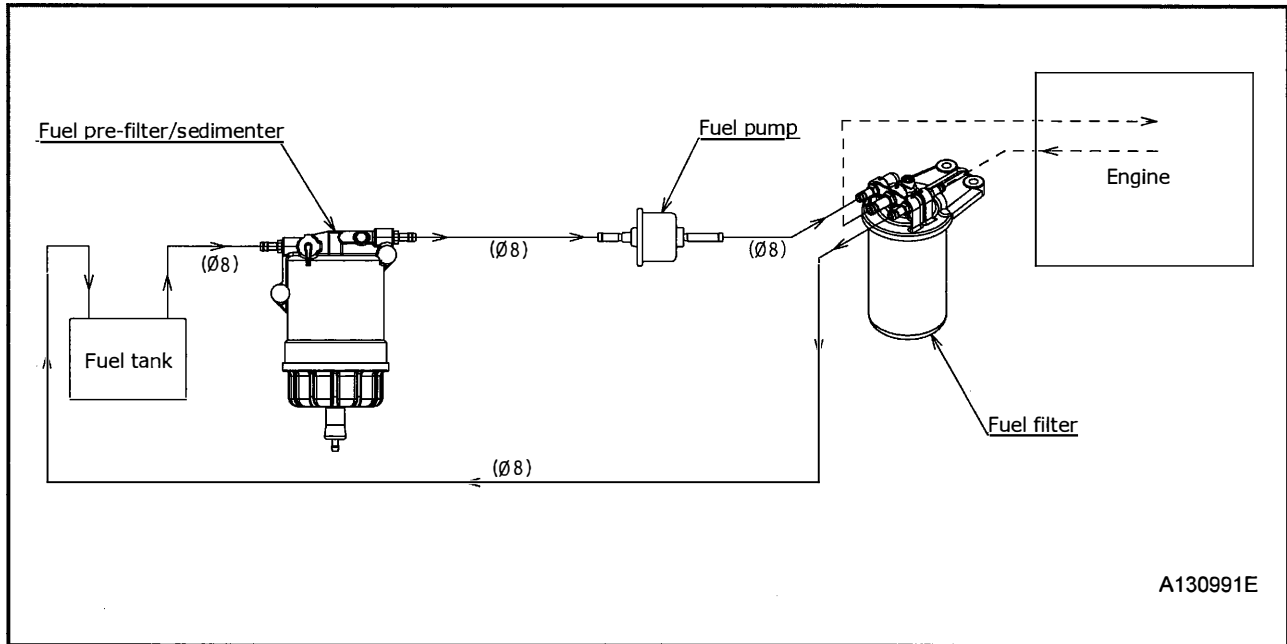

## OPERATION LOG

OPERATION DATE	OPERATION TIME		TOTAL OPERATION HOURS (h)	DISCHARGE AIR PRESS.(MPa)	AMBIENT TEMP.(°C)	DISCHARGE AIR TEMP.(°C)	COOLANT TEMP.(°C)	RATED RPM (rpm,min <sup>-1</sup> )	ENG.OIL REPLACEMENT HOUR (h)	COMP.OIL SUPPLY(L)	REMARKS (INSPECTION/PART CHANGE HISTORY ETC.)
	START TIME	STOP TIME									
. . .	:	:									
. . .	:	:									
. . .	:	:									
. . .	:	:									
. . .	:	:									
. . .	:	:									
. . .	:	:									
. . .	:	:									
. . .	:	:									
. . .	:	:									
. . .	:	:									
. . .	:	:									
. . .	:	:									
. . .	:	:									
. . .	:	:									
. . .	:	:									
. . .	:	:									
. . .	:	:									
. . .	:	:									
. . .	:	:									
. . .	:	:									
. . .	:	:									
. . .	:	:									
. . .	:	:									
. . .	:	:									
. . .	:	:									
. . .	:	:									

# MEMO

---

A series of horizontal dotted lines for writing a memo.

**HOKUETSU INDUSTRIES CO., LTD.**

8TH FLOOR SHINJUKU SAN-EI BLDG,  
22-2 NISHI-SHINJUKU 1-CHOME, SHINJUKU-KU  
TOKYO 160-0023 JAPAN

TEL:81-3-3348-7281

FAX:81-3-3348-7289

URL:<http://www.airman.co.jp>

Copyright (C) 2013 HOKUETSU INDUSTRIES CO., LTD. All Rights Reserved.

**39600 49830**

Printed JUN. 2014

**AIRMAN**  
HOKUETSU INDUSTRIES CO., LTD.